



# SSR AV-5, AV-10 SERIES

## Vacuum Receiver and Filter Chamber

## Technical Specifications

SSR/AV-5 & AV-10 vacuum receivers are used to convey free-flowing granular, powdered or regrind materials in a centralized conveying system.

### Features

#### Standard Features

- Flange mount configuration
- Integral material demand/level sensor
- Internal check valve on material inlet for 2.0", 2.5" and 3.0" Note: Consult factory for line sizes larger than 3.0" OD
- Brushed stainless steel construction. Painted cover assembly
- Removable aluminum material inlet:
  - SSR23-45 —Removable aluminum (2.0-3.5" O.D)
  - SSR85-170 —Removable aluminum (2.5-3.5" O.D)
- SSR/AV-5 receivers include angled, counterweighted discharge throat with gasket seal (SSR23-45 —4" Throat, SSR85-170 —6" Throat)
- Dual atmospheric valves for control of the vacuum and filter cleaning cycle
- Air operated vacuum sequencing valves built into cover of unit. No need for an additional sequence valve
- Low maintenance design. No tools required for filter bag cleaning/changes
- Large filter bag area for low pressure drop and good material/air separation
- Acrylic lined filter bags for better dust release and filter performance
- Auxiliary output provided for control of optional air slide gate
- Quick access latched cover design
- Hopper mounted control of cleaning cycle

#### Optional Features

- 24 VDC control voltage
- Capacitive volume fill sensor in vacuum receiver
- Remote demand sensor for material demand
- Air operated slide gate in lieu of standard discharge (4" slide gate for SSR23-45; 6" slide gate for SSR85-170)
- Distributed I/O cable connection kit
- Special mounting flange pattern (consult factory)
- Riser mount configuration (not available when slide gate option is selected)
- Optional filter media
- 70 degree cone for hard to flow materials (not available on SSR23 and SSR45 models)
- 115 VAC control voltage SSR/AV-10
- Compressed air fluidizing pad system for receiver cone

## Product Diagrams

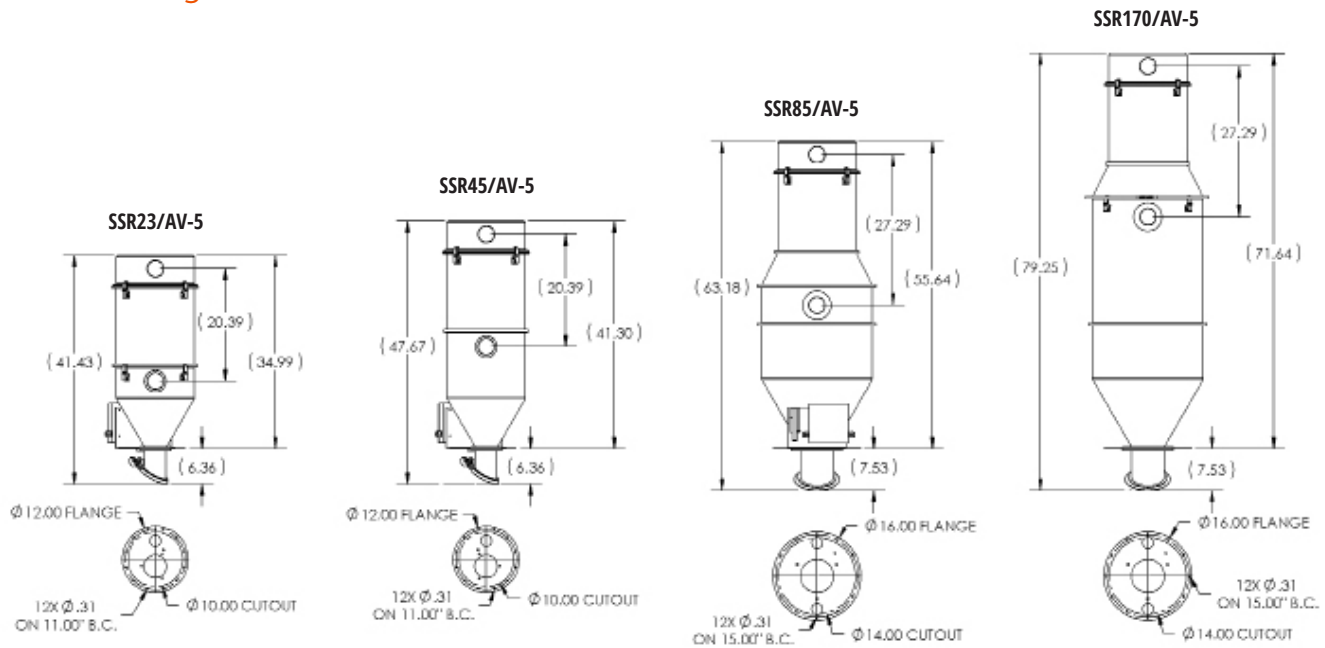

## Application Notes

These receivers should not be used for conveying materials that are not free flowing.  
 Consult factory for all glass-filled material conveying applications.

## Specifications

### SSR-AV-5

Model	Filter Area sq ft (m2)	Inlet/Outlet Range in (mm)	Receiver Capacity cu. ft (lbs)	Receiver Capacity Liters	Dimensions H x W in. (cm)	Shipping Weight lbs (kg)
23	5 (0.46)	2, 2.5, 3 (51, 64, 76)	0.8 (28)	22	35 x 14 (89 x 36)	85 (39)
45		2, 2.5, 3, 3.5 (51, 64, 76, 89)	1.6 (56)	45	41 x 14 (104 x 36)	88 (40)
85		2.5, 3, 3.5 (64, 76, 89)	3.0 (105)	85	56 x 20 (142 x 51)	120 (54)
175			6.0 (210)	170	72 x 20 (183 x 51)	140 (64)

### SSR-AV-10

Model	Filter Area sq ft (m2)	Inlet/Outlet Range in (mm)	Receiver Capacity cu. ft (lbs)	Receiver Capacity Liters	Dimensions H x W in. (cm)	Shipping Weight lbs (kg)
23	10 (0.93)	2, 2.5, 3 (51, 64, 76)	0.8 (28)	22	48 x 14 (123 x 36)	85 (39)
45		2, 2.5, 3, 3.5 (51, 64, 76, 89)	1.6 (56)	45	53 x 14 (135 x 36)	88 (40)
85		2.5, 3, 3.5 (64, 76, 89)	3.0 (105)	85	68 x 20 (172 x 51)	120 (54)
170			6.0 (210)	170	84 x 20 (213 x 51)	140 (64)