



EXTREME DUTY SHREDDER

POWER AND PERFORMANCE FOR TROUBLE-FREE SIZE REDUCTION

Designed for processing plastic waste for reclamation and recycling, large extruder purgings, large reject parts, trim scraps, baled or loose film, synthetic fiber, wood processing scrap, medical waste, cardboard, paper and carpet. All of the SXS Series shredders feature the following:

Features

- Sturdy “swing-style” ram minimizes space and allows product to fall into the rotor
- Serrated ram plate for holding product into the rotor
- Outboard mounted bearings reduces contamination
- Square cutters that are reversible for quick changes
- Large 29.5” (750mm) diameter rotor for positive ingestion
- Bolted in cutter seat for easy removal and maintenance
- Abrasion resistant rotor standard for long life
- Dual motor driven for even HP displacement on both shaft ends
- Two speed ram hydraulics

Options

- Hydraulic screen cradle
- Rotor cooling
- PLC with display
- Chamber wear protection
- Infeed and discharge conveyors
- Easily configured with 2nd stage granulation



SXS SERIES



Standard Description	SXS 1500	SXS 2000	SXS 3000
Hopper Feed Opening, in (mm)	102.4 x 63.8 (2600 x 1620)	102.4 x 79.5 (2600 x 2020)	100.0 x 108.7 (2600 x 2760)
Usable Area of Cutting Chamber, in (mm)	59.1 x 58.7 (1500 x 1490)	59.1 x 74.8 (1500 x 1900)	59.1 x 106.3 (1500 x 2700)
Rotor speed (rpm @ 60 Hz)	54	54	54
Rotor Diameter, in (mm)	29.5 (750)	29.5 (750)	29.5 (750)
Number of D2 Rotor Cutters (60mm x 60mm)	76	96	136
Number of D2 Bed Knives (4-edge)	4	5	7
Standard Motor, hp (kW)	2x100 (2x75)	2x100 (2x75)	2x150 (2x110)
Motor of Hydraulic device, hp (kW)	15 (11)	15 (11)	15 (11)
Screen Sizes Available, in (mm)	1-4 (20-100)	1-4 (20-100)	1-4 (20-100)
Mounted Knife-holders	Included	Included	Included
Hopper for manual/conveyor feeding	Included	Included	Included
Hydraulic feeding ram	Included	Included	Included
Two speed Turbo-Hydraulic	Included	Included	Included
Ram comb plate	Included	Included	Included
Control panel SPS	Included	Included	Included
Ampere-Meter in control cabinet	Included	Included	Included



Standard hardened rotor with replaceable cutters and cutter holders designed for high throughput of the toughest materials



Large Diameter Rotor with "Swing Style" Ram with Serrated Front Surface



Two Stage Hydraulics with Air Cooler For Long Life

Dimensions	SXS 1500	SXS 2000	SXS 3000
Length A, in (mm)	141.7 (3600)	141.7 (3600)	141.7 (3600)
Length B, in (mm)	102.4 (2600)	102.4 (2600)	102.4 (2600)
Length C, in (mm)	34.3 (870)	34.3 (870)	34.3 (870)
Length D, in (mm)	131.9 (3350)	131.9 (3350)	131.9 (3350)
Length E, in (mm)	99.9 (2540)	99.9 (2540)	99.9 (2540)
Width F, in (mm)	125.9 (3200)	154.7 (3930)	192.9 (4900)
Width G, in (mm)	63.7 (1620)	79.5 (2020)	111 (2820)

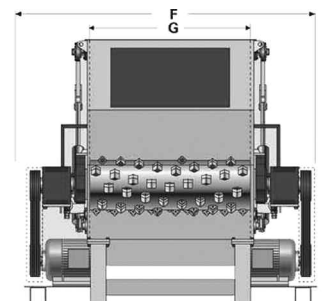
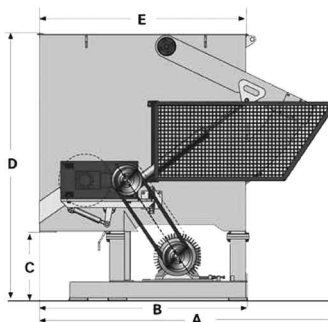

Sterling New Berlin
2900 S 160th Street
New Berlin, WI 53151 USA
Tel: +1 262 641 8610
Fax: +1 262 641 8653
www.sterlco.com

Sterling Schaumburg
1100 E Woodfield Rd #550
Schaumburg, IL 60173 USA
Tel: +1 847 273 7700
Fax: +1 847 273 7804

Sterling India
Gat No. 191/1, Sandbhor Complex,
Mhalunge, Chakan, Tal Khed,
Dist. Pune 410501, India
Tel: +91 21 35329112
Fax: +91 20 40147576

Sterling Warsaw
ul. Dziakowa 115
02-234 Warszawa
Tel: +48 22 390 9720
Fax: +48 22 390 9724

Sterling Suzhou
109 Xingpu Road SIP
Suzhou, China 215126
Tel: +86 512 8717 1919
Fax: +86 512 8717 1916

