

SVL SERIES COMPRESSED AIR LOADERS

Sterling's compact SVL loaders are designed to provide trouble-free conveying using compressed air. These highly efficient, self-contained loaders use compressed air and an efficient venturi to draw material from drums, bins, material bags, or gaylords.

The material is drawn through the venturi under vacuum and then conveys into the receiver using the pressurized air. The material is separated from the air stream and is deposited into the bin or process machine. An efficient filtering system is used to capture material fines before air is exhausted into the plant. A simple control assembly is easy to operate and makes this loader a good choice for many single loading material conveying applications. Choose the configuration that is correct for your application.



SVL-A and SVL-B Series Standard Features

- Receiving hopper for material
- Standard flange with quick release fasteners
- Control assembly with low power consumption solenoid – 115/1/50-60 Hz
- Air filter/regulator combination with pressure gauge
- Capacitive sensor for material demand with 16.4 foot (5 meter) quick disconnect cable to control venturi/wand assembly with quick connect air line fittings
- 3/8" poly hose air line – 10 ft.
- 1-1/4" standard vinyl flexible hose – 10 ft.
- Two hose clamps for 1-1/4" vinyl flex hose

SVL-C Series Standard Features

Same features as SVL-B plus the following:

- Second venturi/wand assembly with quick connect air line fittings
- 1-1/4" O.D. wye-tube with coupler to attach to material inlet on receiving hopper
- Additional 3/8" poly hose air line – 10 ft.
- Additional Two hose clamps for 1-1/4" vinyl flex hose
- Additional control assembly for second venturi assembly including air regulator with pressure gauges

SVL-D Series Standard Features

- Drum fill evacuation system
- Mobile drum stand on casters (two locking/two swivel) with adjustable arm and filtered 22" dia. drum cover
- Control assembly with low power consumption solenoid – 115/1/50-60Hz
- Capacitive sensor for material demand (inside drum) with 16.4 ft (5 meter) quick disconnect cable venturi/wand assembly with quick connect air fittings
- 1-1/4" standard vinyl flexible hose -10 ft.
- Two hose clamps for 1-1/4" vinyl flex hose
- 3/8" poly hose air line - 10 ft.

Options

- Direct mount flange (with remote mount level sensor)
- Bin mount flange adapter with SSR 6-45 bolt circle (level sensor mounted to flange)¹
- Sight glass assembly for machine mount of SVL loader with sensor mounted to glass assembly¹
- Torpedo magnet for sight glass assembly¹
- Dust bag kit with tube in lieu of standard filter for dusty regrinds (not available for SVL-A loaders)¹
- Universal adapter for grinder take-off attachment to fit up to 2" O.D. Material line connection (slips over existing tube stub)
- 230/1/50-60 voltage

¹ These options are not available on SVL-D model

SVL SERIES

Compressed Air Loaders

SPECIFICATIONS

Model	Maximum Throughput, lbs./hr (kg/hr) ¹	Shipping Weight ² , lbs. (kg)	Operating Voltage (watt)	Noise Level, dbA	Max. Conveying Distance, ft (meters)	Compressed Air Supply, PSI (bar)	Compressed Air Consumption, scfm (l/min)	Vacuum Performance, H ₂ O (kPa)	Typical Comp. Air Consumption scfm (l/min) psig (bar)	Max. Product Temp., F° (C°)	Optional Sight Glass Cap., cu. ft. (liters) lbs. (gram)
SVL-A	475 (215) ³	16.6-20.6 (7.5-9.3)	115/1/50-60 (2 watt)	< 75	Horizontal - 30 (9.14)	70-90 (5-6)	25.9 (733) (Based on 100% continuous use)	-42" (-11)	8-10 scfm (227-283 l/min) @ 80 psig (6 bar) based on 30% duty cycle for intermittent use	176 (80)	.005 (.140) .20 (91)
SVL-B		19.8-23.8 (9.0-10.8)									
SVL-C		29.6-33.6 (13.4-15.2)									
SVL-D		125.0 (56.7)									

1 Maximum throughput of material is based on conveying typical materials at close distances (beside-the-press)

2 All weights include 10 lbs. for packing materials

3 Maximum conveying distance, feet (meter) = horizontal 30 (9.14), vertical 12 (3.7)

MODEL NAMING MATRIX

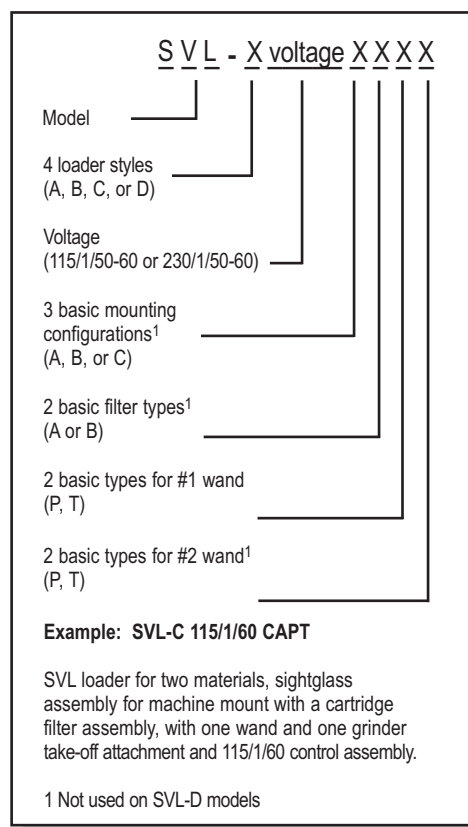

MODEL DESCRIPTION

SVL-A - pellets only (single inlet)

The SVL-A is a single inlet venturi loader used to convey clean, pelletized material into a process. Price includes one pick-up material probe and single inlet control assembly. 115 VAC.

SVL-B - pellets or regrind (single inlet)

The SVL-B is a single inlet venturi loader used to convey clean pellets or regrind material into a process. Price includes one pick-up device and single inlet control assembly. 115 VAC.

SVL-C - pellets or regrind (two inlet)

The SVL-C is a single inlet venturi loader with a special wye tube attachment that allows conveying of two materials (usually a virgin and regrind material) into a process. Price includes two pick-up devices and two venturi control assemblies. 115 VAC.

SVL-D - pellet or regrind (drum fill evacuation system)

The SVL-D is a mobile stand with a single inlet conveying pellets or regrind to fill material drums. Price includes drum stand, one pick-up device, filtered drum cover and single inlet control assembly.

SVL-D - drum fill stand evacuation system with premium control option

Same features as standard SVL-D plus enhanced control. Control features include:

- Remote capacitive sensor with removable 20 ft patch cord to mount in grinder bin
- Local sensor in barrel to indicate barrel high level
- Low power consumption solenoid
- Manual operation feature of solenoid for manual loading
- Alarm light - visual alarm
- Alarm horn - audible alarm
- Adjustable fill time of unload cycle
- Energy-saving fill timer for timed fill cycle and pause until grinder high level is obtained
- Alarm on barrel full - high level condition
- Alarm on grinder and barrel full - high level condition
- No load alarm
- Adjustable no load alarm counter
- Alarm silence
- Power cord
- Control mounted to barrel fill stand
- Specify voltage

Body Type: (1st position of model number)

- A: Single inlet for clean pellets ONLY
- B: Single inlet for pellets or regrind
- C: Single inlet tank with WYE tube inlet two materials
- D: Drum fill station with one inlet for pellets or regrind

Voltage: (2nd position of model number)

- 110/1/50: 115/1/60 VAC Control Assembly
- 230/1/60: 220/1/50 VAC Control Assembly

Mounting: (3rd position of model number)

- A: Direct Mount (Less Flange Options - Standard)
- B: Bin Mount flange adapter (with SSR 06-45 bolt pattern)
- C: Sight glass assembly for machine mount

Filter: (4th position of model number)

- A: Cartridge Filter for pellets and clean regrind
- B: Dust bag kit with tube in lieu of standard filter for dusty regrinds (not available on SVL-D model)

Wand Selection: (5th and 6th positions of model number)

- P: Pickup - vertical wand style, 1-1/4" O.D.
- T: Takeoff - horizontal tube with coupler for attachment to 1-1/4" material take-off

SVL SERIES



Compressed Air Loaders

SVL-A SPECIFICATIONS - ONE MATERIAL CONVEYING (CLEAN PELLETS ONLY)

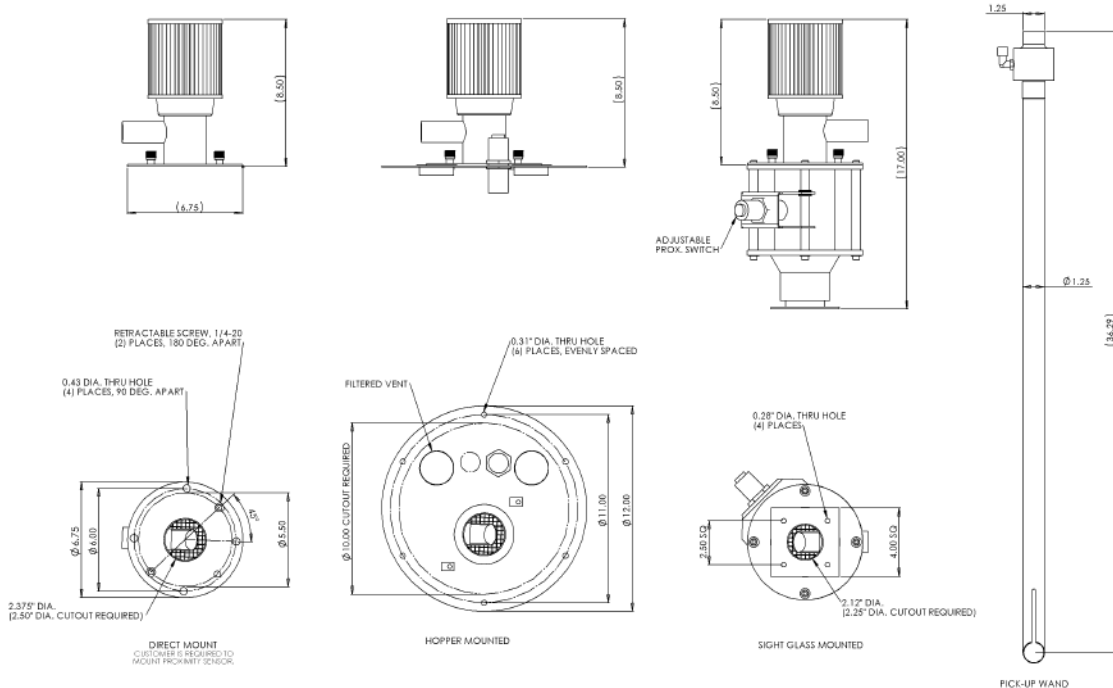

SVL-B SPECIFICATIONS - ONE MATERIAL CONVEYING (PELLETS OR CLEAN REGRIND)

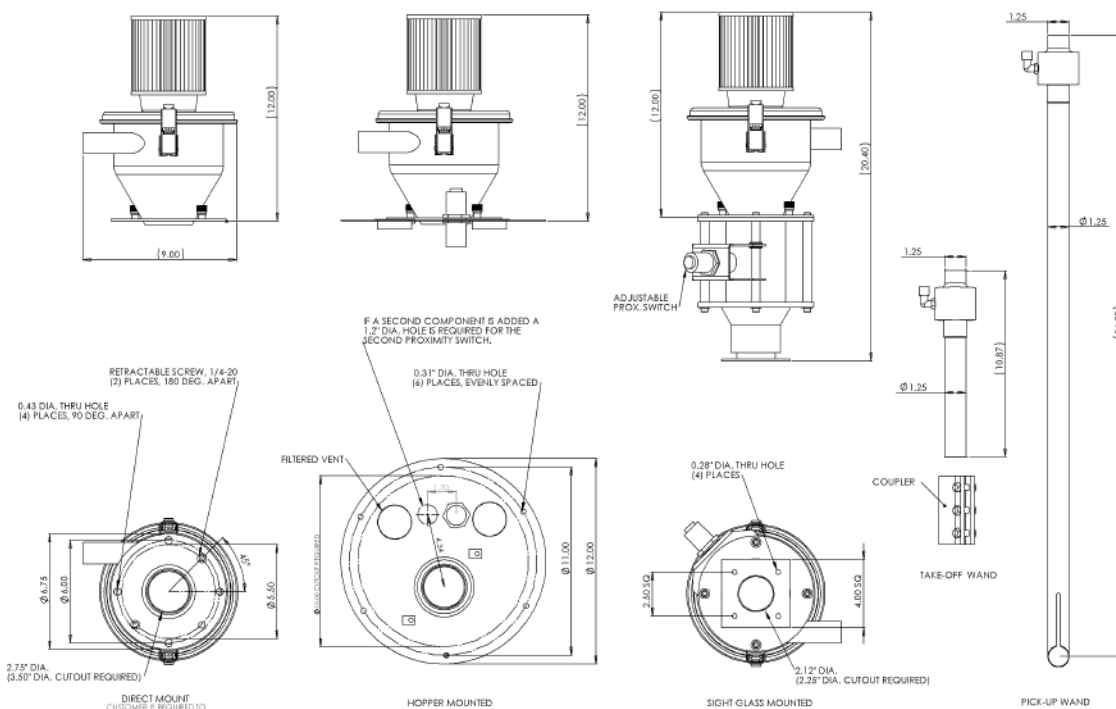

Note - Grinder or take-off tube connection is 1.25" O.D.

