

SCRAP HANDLING AND RECLAIM FOR A VARIETY OF PROCESSES

STE Series economy trim re-feed systems are designed to run at a set percentage of extruder speed (rpm). Signal isolation circuitry receives extruder tachometer signals to determine system speed. Each auger can be adjusted independently, using the controls on the front panel.

STE fluff feed hoppers are designed to feed edge trim back into an extruder at a maximum rate 20% of the extruder output.

NOTE: Cannot be used with grooved feed throats.



Features

- NEMA 12 enclosure
- Up to 20% re-feed rate¹
- Machine-mount flange
- Dependable auger metering
- Mild steel material contact surfaces
- IR compensation
- Vertical mix auger, horizontal fluff metering auger
- Extruder following signal isolator
- Individual voltmeters
- Horizontal and vertical drive DC motors (SCR) 180 VDC
- Individual speed adjustments on fluff auger and Verti-blend mixer
- 230/1/60 supply voltage

¹ Re-feed rate is based on feeding 1 mil, medium slip LDPE film scrap to a die limited extrusion system. If the system is limited by the extruder, some loss in output rate may occur when feeding higher percentages of fluff.

Options

- Special voltage, please specify
- High level sensor with delay timer
- 90° feed pedestal
- Special design feed pedestal
- Fluff supply hopper with bottom clean-out door; includes safety switch
- Special mounting flange or throat adapter (extruder throat & flange drawings required)
- Special cyclone hole in fluff hopper cover (exact specifications required)
- Cyclone separators

STE SERIES

Fluff Feed System

STE SERIES FLUFF FEED HOPPER EQUIPMENT SELECTIONS

Model	Extruder Size (screw dia.) In. (mm)	Drive Type
250STE	2.5 (63)	DC

STE SERIES AUGER SPECIFICATIONS

Model	Horizontal Auger		Vertical Auger	
	Power, HP (kW)	Size/dia, in. (mm)	Power, HP (kW)	Size/dia, in. (mm)
250 STE	1/2 (0.373)	1 5/8 (41.3)	1/2 (0.373)	2 1/2-1 3/4 (63.5-44.5)

TYPICAL STE SERIES FLUFF FEED HOPPER

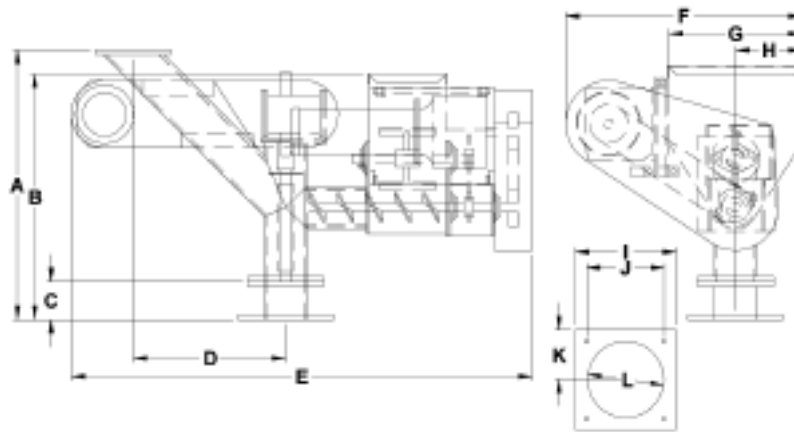

STE SERIES DIMENSIONS

Model	Overall Unit Dimensions (cm is approx.)							
	A, in. (cm)	B, in. (cm)	C, in. (cm)	D, in. (cm)	E, in. (cm)	F, in. (cm)	G, in. (cm)	H, in. (cm)
250 STE	27-3/4 (70)	26-1/8 (66)	4 (10)	16 (41)	47-3/8 (120)	19-3/8 (49)	8-1/4 (21)	4-1/8 (10)

Model	Unit Flange Dimensions (mm is approx.)			
	I, in. (mm)	J, in. (mm)	K, in. (mm)	L, in. (mm)
250 STE	8 (203)	6 (152)	4 (102)	4 (102)

