

WHISPER-QUIET OPERATION

The SPD sound enclosure can be used with Sterling's SPD Series vacuum pump. The two-thirds/one-third clamshell design clamps easily around the pump, providing a minimum of 15+ dba sound reduction.



Features

- 13-gauge diamond-plate aluminum construction
- Two-thirds/one-third clamshell design with latching clamps
- 2.75 flat foam, fire-retardant, high-temperature, oil-resistant insulation
- Resistant to heat and oils
- Baffled air inlet assures maximum attenuation
- Design allows for all-weather installation
- Unit ships fully assembled. Light enough to be lifted over package for installation
- Easy to install
- Easy access for pump service
- Dimensions: 38 L x 40 W x 43 H (96 cm x 102 cm x 109 cm)

Options

- No available options

SPD SERIES

Sound Enclosure

SPECIFICATIONS

Dimensions, in. (cm)
38 x 40 x 43 (78 cm L x 78 cm W x 215 cm H)

*APD Pump sold separately

DIMENSIONS

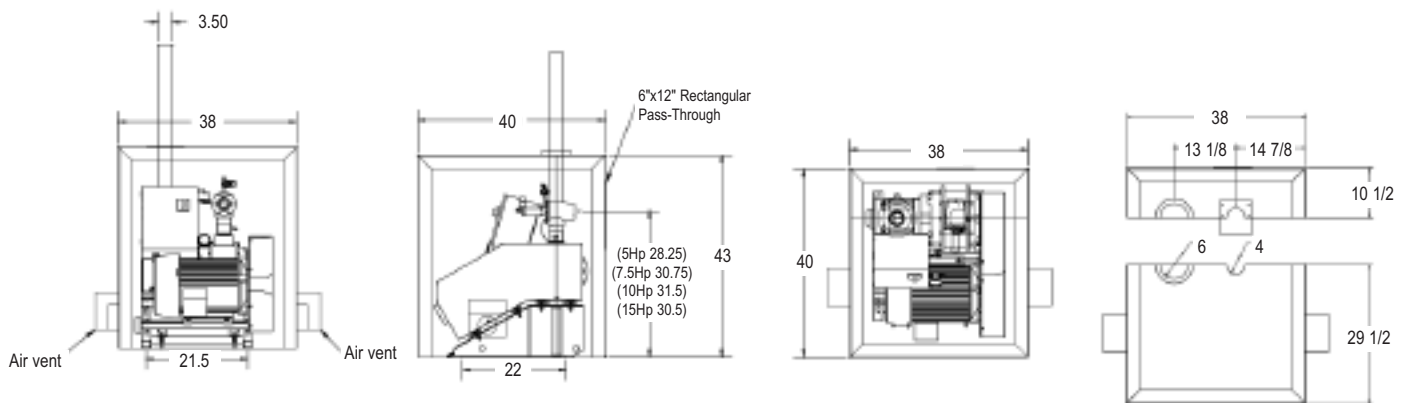

Standard SPD Pump Configuration
P/N: A0573898

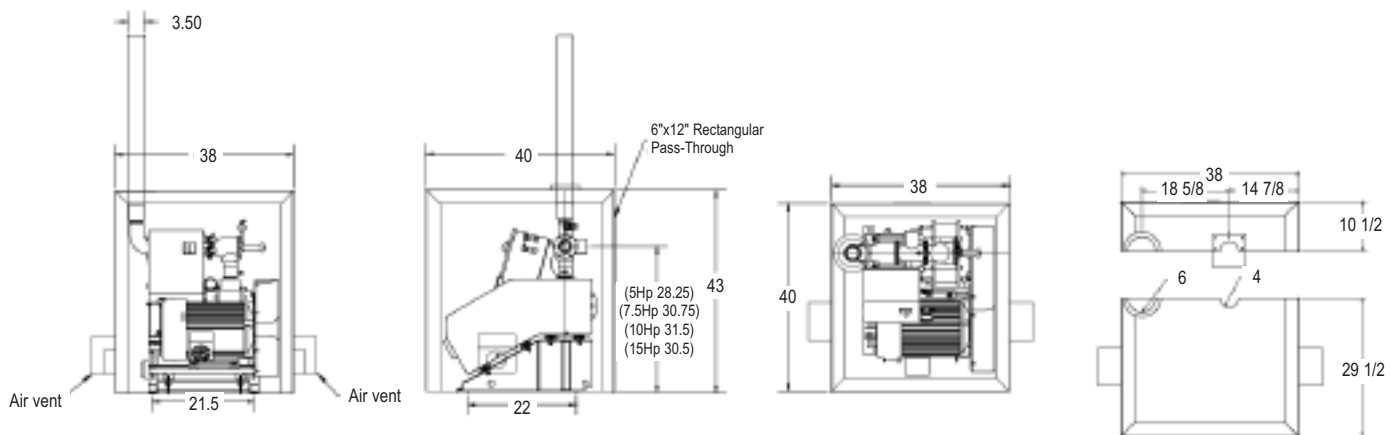

Non-Reversing SPDB Pump Configuration
P/N: A0574776