

ADVANCED TECHNOLOGY FOR ENHANCED PERFORMANCE

SMC Series air-cooled portable chillers from Sterling provide 2 to 30 ton cooling capacities with very compact footprints. These chillers feature a unique enclosure design that simplifies service and maintenance and conserves valuable production floor space. Incorporate these chillers into your planned or existing production layout easily and effectively.

All SMC Series portable chillers have an operating leaving water temperature range of 35°F to 65°F (2°C to 18°C). For applications outside this range, consult factory. See pages 41-42 for flow and pressure considerations and pump curves.



Features

- Non-ferrous piping
- External fill/drain/sight glass
- Valved Process water connections
- Low Process water: pressure switch 2-3.5 hp, flow switch 5-40 hp
- Swivel casters: 2.5" (2-3.5 hp), 4" (5-15 hp), 5" w/lock (optional on 5-15 hp, standard on 20-40 hp)
- Single pump models only: Pressure-actuated Process water bypass valve for system protection
- To Process 2.5" dual scale liquid-filled pressure gauge
- Fully insulated refrigeration and process piping
- High and low refrigerant pressure cut-outs
- High discharge temperature cut-out (2-10 hp models)
- High pressure spring-actuated relief valve
- Filter dryer, sight glass, balanced-port thermal expansion valve, multiple refrigeration access ports
- Hot gas bypass capacity control
- Hot gas bypass and liquid line shutoff valves (5 to 30 hp)
- Scroll compressors (2-30 hp)
- R-22 refrigerant
- 1 year warranty on compressor and labor
- 2 year parts warranty, 3 year limited warranty on controller

Options

- Automatic water makeup valve¹
- Process water sidestream 50µ filter w/ flowmeter¹
- General fault indicator, 85 dB @ 2 ft with audible alarm buzzer and silence button or 100 dB @ 10 ft audible alarm horn/108,000 peak candle-power, 80 flash/min visual alarm strobe and silence button. Alarm conditions include high and low water temperature, low water flow, and high and low refrigerant pressure¹
- Compressor hour meter¹
- RS232 or RS485 communications
- Recirculation pump (not available on 2 and 3.5 hp)
- High pressure fans; provides additional 0.3" WG static pressure on fan discharge (5-15 hp only), required where exiting air is exhausted through ductwork
- Crankcase pressure regulating (CPR) valve to prevent compressor motor overloading, required for process water leaving temperature of 66°F to 75°F
- 304 SS reservoir tank (not available on 2 and 3.5 hp)
- Mounting rails and/or mounting feet (not available on 2 and 3.5 hp)
- UL-Labeled electrical subpanel
- 380/3/50 or 575/3/60 operating voltage²
- Variable-speed fans (low ambient), provides sound attenuation in ambient temperatures below 95°F² (5-15 hp only)
- NEMA-12 control access window²

- 1 Field-retrofit option
- 2 Additional lead time

SMC SERIES

Air-Cooled Portable Chillers

SPECIFICATIONS

Model	Compressor, HP	Compressor type	Evaporator type	Condenser type	Reservoir, gallons	Pumps	Discharge air openings	Discharge air, cfm
SMCA 2	2	Hermetic scroll, with compressor staging on 20-30 hp tandems	SS copper-brazed plate	Aluminum fin/copper tube with washable filters	6 (polyethylene)	1 hp, 304 SS	1 @ 18.5"	1475
SMCA 3.5	3.5				6 (polyethylene)	1 hp, 304 SS	1 @ 18.5"	2350
SMCA 5	5				20 (polyethylene)	1 hp, 304 SS	1 @ 27"	3400
SMCA 7.5	7.5				20 (polyethylene)	1 hp, 304 SS	1 @ 27"	5100
SMCA 10	10				40 (polyethylene)	2 hp, 304 SS	2 @ 27"	5800
SMCA 15	15				40 (polyethylene)	2 hp, 304 SS	2 @ 27"	10000
SMCA 20	2 @ 10				80 (polyethylene)	5 hp, 304 SS	25" x 18.5"	10200
SMCA 25	2 @ 13				80 (polyethylene)	5 hp, 304 SS	25" x 18.5	13300
SMCA 30	2 @ 15				80 (polyethylene)	5 hp, 304 SS	25" x 18.5	18150

NOTE: Nominal operating parameters for SMC air-cooled chillers are 50°F leaving water temperature at 2.4 gpm per ton, with 95°F ambient air. For 50 Hz applications, multiply capacity by 0.83. Nominal 60 Hz flow rate must be maintained.

Model	Nominal cooling cap., tons ¹			Process connections, in. NPT				Water flow, gpm ²	FLA 1 pump ³		FLA 2 pumps ³	
	No pump	1 pump	2 pump	1 pump	2 pump	no pump/ no tank	1 pump/ no tank		Rated	Running	Rated	Running
SMCA 2	1.9	1.7	n.a.	1	n.a.	n.a.	n.a.	4.6	8.0	6.9	n.a.	n.a.
SMCA 3.5	3.3	3.1	n.a.	1	n.a.	n.a.	n.a.	7.9	10.9	8.8	n.a.	n.a.
SMCA 5	4.8	4.6	4.5	1.5/2.0	2.0	1.5	1.5/2.0	11.1	14.0	11.0	14.9	11.9
SMCA 7.5	6.6	6.4	6.3	1.5/2.0	2.0	1.5	1.5/2.0	15.2	18.2	14.6	19.1	15.5
SMCA 10	9.9	9.5	9.4	1.5/3.0	2.0/3.0	1.5	1.5/2.0	22.8	26.1	21.8	27.8	23.5
SMCA 15	14.5	14.1	14.0	2.0/3.0	2.5/3.0	2.0	2.0/3.0	33.9	33.3	27.5	35.0	29.2
SMCA 20	19.4	18.4	18.0	2.0/3.0	2.5/3.0	2.0	2.0/3.0	46.5	48.3	42.0	51.4	45.1
SMCA 25	23.9	22.8	22.4	2.0/3.0	2.5/3.0	2.0	2.0/3.0	57.2	62.1	48.3	65.2	51.4
SMCA 30	29.2	28.2	27.8	2.0/3.0	2.5/3.0	2.0	2.0/3.0	70.2	74.1	64.4	77.2	67.5

¹ Based on 50°F (10°C) chilled water supply temperature and 95°F (35°C) ambient air. Optional additional process pump hp (kW) reduces chiller capacity by 0.2 tons per hp (0.703 kW ref. cap. per 0.746 kW pump power)

² Based on 2.4 gpm per ton (9.1 lpm per 3.517 kW) nominal 1 pump.

³ FLA at 460/3/60. Multiply 460/3/60 amperage by 2.0 for 208-230/3/60 amperage (0.8 for 575/3/60). An optional oversized process pump adds to the total rated or running chiller amperage. To find the new total chiller amperage, subtract the standard process pump amperage from the optional pump amperage (see table below) and add it to the rated or running amperage.

PUMP OPTIONS

Optional Pump	FLA @ 208-230/1/60	FLA @ 460/3/60	Availability
0.75 hp bronze turbine	5.4	1.5	2 and 3.5 hp models
1 hp SS	6.4	1.8	standard on 2-7.5 hp models
1.5 hp SS	7.5	2.3	2 and 3.5 hp models
2 hp SS	9.6	3.1	2-15 hp models (standard on 10-15 hp)
2 hp SS dual stage	n.a.	2.7	5-7.5 hp models
3 hp SS	12.7	4.2	2-15 hp models
3 hp SS dual stage	n.a.	4.5	5-15 hp models
5 hp SS	n.a.	6.2	5-30 hp models (standard on 20-30 hp)
5 hp SS dual stage	n.a.	6.6	5-15 hp models
7.5 hp bronze	n.a.	9.0	5-15 hp models
7.5 hp SS	n.a.	9.8	20-30 hp models
10 hp SS	n.a.	13.2	10-30 hp models
15 hp SS	n.a.	19.0	20-30 hp models

ELECTRICAL CONTROL FEATURES

- Fully accessible NEMA 12 enclosure
- Non-fused disconnect switch with branch fusing
- Single-point power and ground wiring connection
- Off-the-shelf microprocessor-based PID auto-tuning controller with To Process and Set Point LED readout
- Low and high process water temperature electronic cut-out switch with LCD display
- Graphic control panel w/status lights



ADVANCED TECHNOLOGY FOR ENHANCED PERFORMANCE

SMC Series water-cooled portable chillers from Sterling provide 2 to 40 ton cooling capacities with very compact footprints. These chillers feature a unique enclosure design that simplifies service and maintenance and conserves valuable production floor space. Incorporate these chillers into your planned or existing production layout easily and effectively.

All SMC Series portable chillers have an operating leaving water temperature range of 35°F to 65°F (2°C to 18°C). For applications outside this range, consult factory. See pages 41-42 for flow and pressure considerations and pump curves.



Features

- Non-ferrous piping
- External fill/drain/sight glass
- Valved Process water connections
- Low Process water: pressure switch 2-3.5 hp, flow switch 5-40 hp
- Swivel casters: 2.5" (2-3.5 hp), 4" (5-15 hp), 5" w/lock (optional on 5-15 hp, standard on 20-40 hp)
- Single pump models only: Pressure-actuated Process water bypass valve for system protection
- To Process 2.5" dual scale liquid-filled pressure gauge
- Fully insulated refrigeration and process piping
- High and low refrigerant pressure cut-outs
- High-discharge temperature cut-out (2-10 hp models)
- High pressure spring-actuated relief valve
- Filter dryer, sight glass, balanced-port thermal expansion valve, multiple refrigeration access ports
- Hot gas bypass capacity control
- Hot gas bypass and liquid line shutoff valves (5 to 40 hp)
- Scroll compressors (2-40 hp)
- R-22 refrigerant
- 1 year warranty on compressor and labor
- 2 year parts warranty, 3 year limited warranty on controller

Options

- Automatic water makeup valve¹
- Process water sidestream 50µ filter w/ flowmeter¹
- General fault indicator, 85 dB @ 2 ft with audible alarm buzzer and silence button or 100 dB @ 10 ft audible alarm horn/108,000 peak candle-power, 80 flash/min visual alarm strobe and silence button. Alarm conditions include high and low water temperature, low water flow, and high and low refrigerant pressure¹
- Compressor hour meter¹
- RS232 or RS485 communications
- Recirculation pump (not available on 2 and 3.5 hp)
- High pressure fans; provides additional 0.3" WG static pressure on fan discharge (5-15 hp only), required where exiting air is exhausted through ductwork
- Crankcase pressure regulating (CPR) valve to prevent compressor motor overloading, required for process water leaving temperature of 66°F to 75°F
- 304 SS reservoir tank (not available on 2 and 3.5 hp)
- Mounting rails (standard with SMCR remote air cooled) and/or mounting feet (not available on 2 and 3.5 hp)
- UL-Labeled electrical subpanel
- 380/3/50 or 575/3/60 operating voltage²
- Variable-speed fans (low ambient), provides sound attenuation in ambient temperatures below 95°F² (5-15 hp only)
- NEMA-12 control access window²

¹ Field-retrofit option
² Additional lead time

SMC SERIES

Water-Cooled Portable Chillers

SPECIFICATIONS

Model	Compressor, HP	Compressor type	Evaporator type	Condenser type ¹	Reservoir, gallons	Nominal pump	Condenser water		
							Tower water ² flow, gpm	City water ³ flow, gpm	Water conn., in. NPT
SMCW 2	2	Hermetic scroll, with compressor staging on 20-30 hp tandems	SS copper-brazed plate	Tube-in tube	6 (polyethylene)	1 hp, 304 SS	6.2	4.2	1.0
SMCW 3.5	3.5				6 (polyethylene)	1 hp, 304 SS	10.5	7.2	1.0
SMCW 5	5				20 (polyethylene)	1 hp, 304 SS	15.7	7.9	1.0
SMCW 7.5	7.5				20 (polyethylene)	1 hp, 304 SS	21.3	10.7	1.0
SMCW 10	10			Cleanable shell and tube	40 (polyethylene)	2 hp, 304 SS	32.2	16.1	1.5
SMCW 15	15				40 (polyethylene)	2 hp, 304 SS	47.6	23.8	2.0
SMCW 20	2 @ 10				80 (polyethylene)	5 hp, 304 SS	61.7	31.5	2.0
SMCW 25	2 @ 13				80 (polyethylene)	5 hp, 304 SS	75.9	38.6	2.0
SMCW 30	2 @ 15				80 (polyethylene)	5 hp, 304 SS	93.9	47.6	2.5
SMCW 40	40	Hermetic scroll, with compressor staging on 20-30 hp tandems	shell & tube		80 (304 SS)	7.5 hp, 304 SS	123.0	61.5	3

NOTE: Nominal operating parameters for SMC air-cooled chillers are 50°F leaving water temperature at 2.4 gpm per ton, with 85°F tower water. For 50 Hz applications, multiply capacity by 0.83. Nominal 60 Hz flow rate must be maintained.

1 With cooling water regulating valves; select between tower or city (5-40 hp models)

2 Based on availability of 85° F (29°C) tower water at 25 psi (172.4 kPa/1.7 bars) minimum

3 Based on availability of 70° F (21°C) city water at 25 psi (172.4 kPa/1.7 bars) minimum

Model	Nominal cooling cap., tons ⁴			Process connections, in. NPT				Water flow, gpm ⁵	FLA 1 pump ⁶		FLA 2 pumps ⁶	
	No pump	1 pump	2 pump	1 pump	2 pump	no pump/ no tank	1 pump/ no tank		Rated	Running	Rated	Running
SMCW 2	2.1	1.9	n.a.	1	n.a.	n.a.	n.a.	5.1	12.2	8.3	n.a.	n.a.
SMCW 3.5	3.6	3.4	n.a.	1	n.a.	n.a.	n.a.	8.6	16.4	11.8	n.a.	n.a.
SMCW 5	5.2	5.0	4.9	1.5/2.0	2.0	1.5	1.5/2.0	12.1	12.2	8.3	13.1	9.2
SMCW 7.5	7.1	6.9	6.8	1.5/2.0	2.0	1.5	1.5/2.0	16.6	16.4	11.8	17.3	12.7
SMCW 10	10.7	10.3	10.2	1.5/3.0	2.0/3.0	1.5	1.5/2.0	24.8	22.5	16.7	24.2	18.4
SMCW 15	15.9	15.5	15.3	2.0/3.0	2.5/3.0	2.0	2.0/3.0	37.1	29.7	21.6	31.4	23.3
SMCW 20	21.0	20.0	19.6	2.0/3.0	2.5/3.0	2.0	2.0/3.0	50.4	43.9	34.7	47.0	37.8
SMCW 25	25.7	24.7	24.3	2.0/3.0	2.5/3.0	2.0	2.0/3.0	61.7	55.9	38.2	59.0	41.3
SMCW 30	31.8	30.8	30.4	2.0/3.0	2.5/3.0	2.0	2.0/3.0	76.2	60.1	45.3	63.2	48.4
SMCW 40	41.0	39.5	39.1	2.5/3.0	2.5/3.0	2.5	2.5/3.0	98.4	81.9	63.1	85.0	66.2

4 Based on 50°F (10°C) chilled water supply temperature and 85°F (29°C) tower water. Optional additional process pump hp (kW) reduces chiller capacity by 0.2 tons per hp (0.703 kW ref. cap. per 0.746 kW pump power)

5 Based on 2.4 gpm per ton (9.1 lpm per 3.517 kW) nominal 1 pump.

6 FLA at 460/3/60. Multiply 460/3/60 amperage by 2.0 for 208-230/3/60 amperage (0.8 for 575/3/60). An optional oversized process pump adds to the total rated or running chiller amperage. To find the new total chiller amperage, subtract the standard process pump amperage from the optional pump amperage (see table on next page) and add it to the rated or running amperage.

SMC SERIES

Water-Cooled Portable Chillers

PUMP OPTIONS

Optional Pump	FLA @ 208-230/1/60	FLA @ 460/3/60	Availability
0.75 hp bronze turbine	5.4	1.5	2 and 3.5 hp models
1 hp SS	6.4	1.8	standard on 2-7.5 hp models
1.5 hp SS	7.5	2.3	2 and 3.5 hp models
2 hp SS	9.6	3.1	2-15 hp models (standard on 10-15 hp)
2 hp SS dual stage	n.a.	2.7	5-7.5 hp models
3 hp SS	12.7	4.2	2-15 hp models
3 hp SS dual stage	n.a.	4.5	5-15 hp models
5 hp SS	n.a.	6.2	5-30 hp models (standard on 20-30 hp)
5 hp SS dual stage	n.a.	6.6	5-15 hp models
7.5 hp bronze	n.a.	9.0	5-15 hp models
7.5 hp SS	n.a.	9.8	20-30 hp models (standard on 35-40 hp)
10 hp SS	n.a.	13.2	10-30 hp models
15 hp SS	n.a.	19.0	20-30 hp models

ELECTRICAL CONTROL FEATURES

- Fully accessible NEMA 12 enclosure
- Non-fused disconnect switch with branch fusing
- Single-point power and ground wiring connection
- Off-the-shelf microprocessor-based PID auto-tuning controller with To Process and Set Point LED readout
- Low and high process water temperature electronic cut-out switch with LCD display
- Graphic control panel w/status lights

SMC SERIES

Water-Cooled Portable Chillers

DIMENSIONS: SMCW 2-7.5

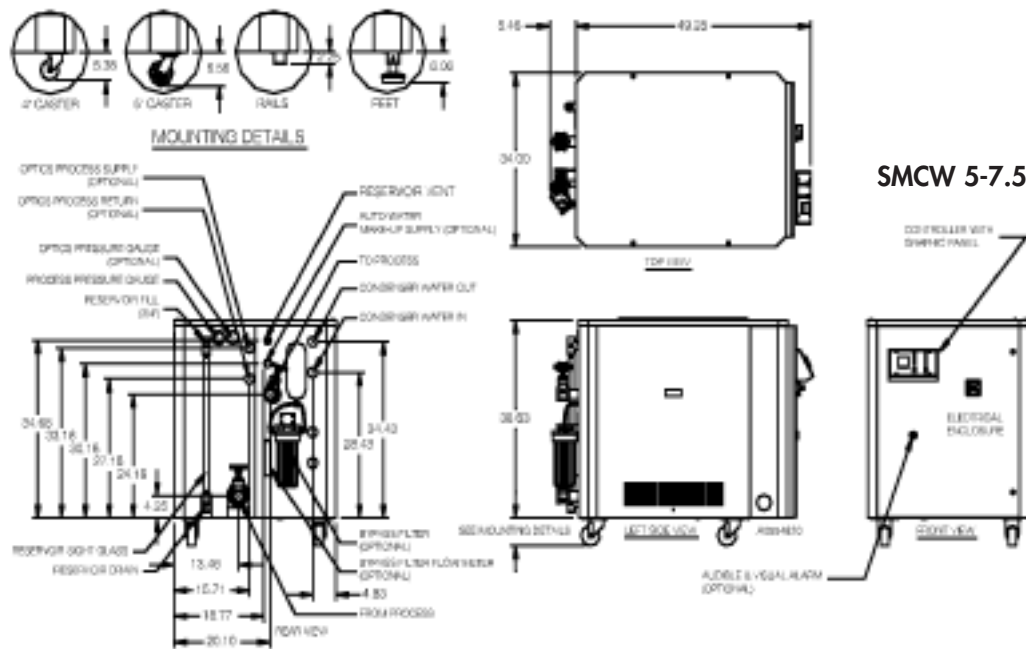
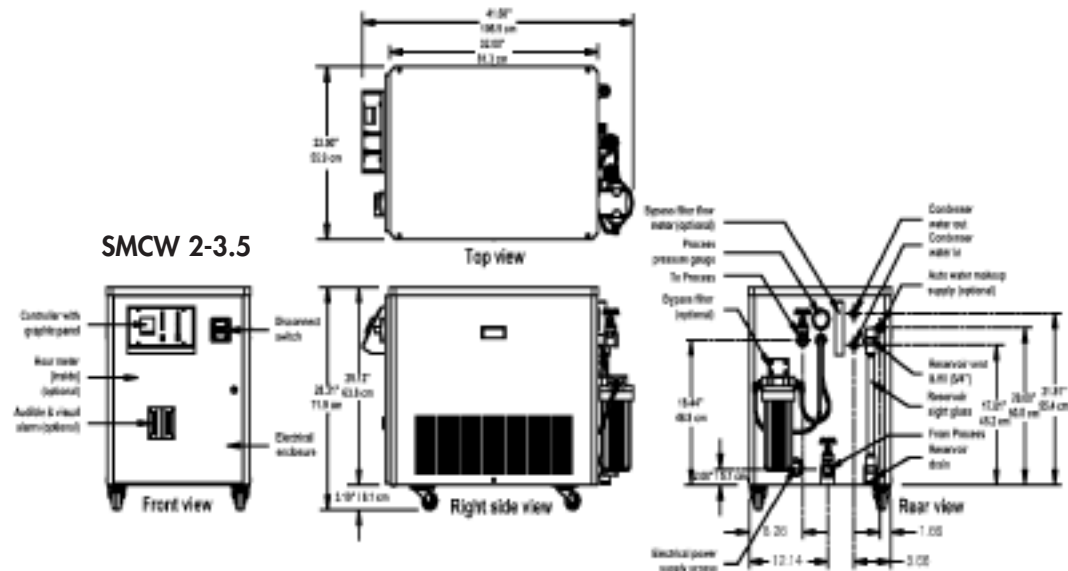

WEIGHTS: SMCW 2-7.5

Model	Dry weight, lbs.	Ship. weight, lbs.	Oper. weight, lbs.
SMCW 2	333	363	383
SMCW3.5	362	392	412
SMCW 5	637	787	970
SMCW 7.5	727	877	1060

NOTES: Weights are for standard chiller. Some optional features will increase weight. Operating weight is with a full reservoir tank of water.

ADVANCED TECHNOLOGY FOR ENHANCED PERFORMANCE

SMC Series remote air-cooled portable chillers from Sterling provide 5 to 40 ton cooling capacities with very compact footprints. These chillers feature a unique enclosure design that simplifies service and maintenance and conserves valuable production floor space. Incorporate these chillers into your planned or existing production layout easily and effectively.

All SMC Series portable chillers have an operating leaving water temperature range of 35°F to 65°F (2°C to 18°C). For applications outside this range, consult factory. SMCR chillers are charged with 25 psi nitrogen for shipping purposes.

Note: Remote condensers are not designed to be used indoors.



Features

- Non-ferrous piping
- External fill/drain/sight glass
- Valved Process water connections
- Low Process water: pressure switch 2-3.5 hp, flow switch 5-40 hp
- Mounting rails (standard with SMCR remote air cooled) or mounting feet
- Single pump models only: Pressure-actuated Process water bypass valve for system protection
- To Process 2.5" dual scale liquid-filled pressure gauge
- Fully insulated refrigeration and process piping
- High and low refrigerant pressure cut-outs
- High-discharge temperature cut-out (2-10 hp models)
- High pressure spring-actuated relief valve
- Filter dryer, sight glass, balanced-port thermal expansion valve, multiple refrigeration access ports
- Hot gas bypass capacity control
- Hot gas bypass and liquid line shutoff valves (5 to 40 hp)
- Scroll compressors (2-40 hp)
- R-22 refrigerant
- 1 year warranty on compressor and labor
- 2 year parts warranty, 3 year limited warranty on controller

Options

- Automatic water makeup valve¹
- Process water sidestream 50µ filter w/ flowmeter¹
- General fault indicator, 85 dB @ 2 ft with audible alarm buzzer and silence button or 100 dB @ 10 ft audible alarm horn/108,000 peak candle-power, 80 flash/min visual alarm strobe and silence button. Alarm conditions include high and low water temperature, low water flow, and high and low refrigerant pressure¹
- Compressor hour meter¹
- RS232 or RS485 communications
- Recirculation pump
- Crankcase pressure regulating (CPR) valve to prevent compressor motor overloading, required for process water leaving temperature of 66°F to 75°F
- 304 SS reservoir tank (std on 40 hp)
- UL-Labeled electrical subpanel
- 380/3/50 or 575/3/60 operating voltage²
- NEMA-12 control access window²

¹ Field-retrofit option

² Additional lead time

SMC SERIES

Remote Air-Cooled Portable Chillers

SPECIFICATIONS

Model	Compressor, HP	Compressor type	Evaporator type	Condenser type	Reservoir, gallons	Nominal pump	Refrigeration connections	
							Discharge, in. dia. ODS	Liquid, in. dia. ODS
SMCR 5	5	Hermetic scroll, with compressor staging on 20-30 hp tandems	SS copper-brazed plate	Outdoor aluminum fin/copper tube	20 (polyethylene)	1 hp, 304 SS	0.625	0.625
SMCR 7.5	7.5				20 (polyethylene)	1 hp, 304 SS	0.875	0.625
SMCR 10	10				40 (polyethylene)	2 hp, 304 SS	1.125	0.625
SMCR 15	15				40 (polyethylene)	2 hp, 304 SS	1.125	0.625
SMCR 20	2 @ 10				80 (polyethylene)	5 hp, 304 SS	1.375	0.875
SMCR 25	2 @ 13				80 (polyethylene)	5 hp, 304 SS	1.375	0.875
SMCR 30	2 @ 15				80 (polyethylene)	5 hp, 304 SS	1.375	0.875
SMCR 40	40				Hermetic scroll, with compressor staging	Shell & tube		80 (304 SS)

NOTE: Nominal operating parameters for SMC air-cooled chillers are 50°F leaving water temperature at 2.4 gpm per ton, with 95°F ambient air. For 50 Hz applications, multiply capacity by 0.83. Nominal 60 Hz flow rate must be maintained.

Model	Nominal cooling cap., tons ¹			Process connections, in. NPT				Water flow, gpm ²	FLA 1 pump ³		FLA 2 pumps ³	
	No pump	1 pump	2 pump	1 pump	2 pump	no pump/ no tank	1 pump/ no tank		Rated	Running	Rated	Running
SMCR5	4.8	4.6	4.5	1.5	2.0	1.5	1.5/2.0	11.1	12.2	9.2	13.1	10.1
SMCR 7.5	6.6	6.4	6.3	1.5	2.0	1.5	1.5/2.0	15.3	16.2	12.8	17.3	13.7
SMCR 10	9.9	9.5	9.4	1.5	2.0	1.5	1.5/2.0	22.8	22.5	18.2	24.2	19.9
SMCR 15	14.5	14.1	14.0	2.0	2.5	2.0	2.0/3.0	33.9	29.7	23.9	31.4	25.6
SMCR 20	19.4	18.4	18.0	2.0/3.0	2.5/3.0	2.0	2.0/3.0	46.5	43.9	37.6	47.0	40.7
SMCR 25	23.8	22.8	27.8	2.0/3.0	2.5/3.0	2.0	2.0/3.0	57.2	55.9	42.1	59.0	45.2
SMCR 30	29.2	28.2	27.8	2.0/3.0	2.5/3.0	2.0	2.0/3.0	70.2	60.0	50.4	63.2	53.5
SMCR 40	36.9	35.4	35.0	2.5/3.0	2.5/3.0	2.5	2.5/3.0	88.6	81.9	68.8	85.0	58.0

¹ Based on 50°F (10°C) chilled water supply temperature and 95°F (35°C) ambient air. Optional additional process pump hp (kW) reduces chiller capacity by 0.2 tons per hp (0.703 kW ref. cap. per 0.746 kW pump power)

² Based on 2.4 gpm per ton (9.1 lpm per 3.517 kW) nominal 1 pump.

³ FLA at 460/3/60. Multiply 460/3/60 amperage by 2.0 for 208-230/3/60 amperage (0.8 for 575/3/60). An optional oversized process pump adds to the total rated or running chiller amperage. To find the new total chiller amperage, subtract the standard process pump amperage from the optional pump amperage (see table on next page) and add it to the rated or running amperage.

SMC SERIES

Remote Air-Cooled Portable Chillers

PUMP OPTIONS

Optional Pump	FLA @ 208-230/1/60	FLA @ 460/3/60	Availability
0.75 hp bronze turbine	5.4	1.5	2 and 3.5 hp models
1 hp SS	6.4	1.8	standard on 2-7.5 hp models
1.5 hp SS	7.5	2.3	2 and 3.5 hp models
2 hp SS	9.6	3.1	2-15 hp models (standard on 10-15 hp)
2 hp SS dual stage	n.a.	2.7	5-7.5 hp models
3 hp SS	12.7	4.2	2-15 hp models
3 hp SS dual stage	n.a.	4.5	5-15 hp models
5 hp SS	n.a.	6.2	5-30 hp models (standard on 20-30 hp)
5 hp SS dual stage	n.a.	6.6	5-15 hp models
7.5 hp bronze	n.a.	9.0	5-15 hp models
7.5 hp SS	n.a.	9.8	20-30 hp models (standard on 35-40 hp)
10 hp SS	n.a.	13.2	10-30 hp models
15 hp SS	n.a.	19.0	20-30 hp models

ELECTRICAL CONTROL FEATURES

- Fully accessible NEMA 12 enclosure
- Non-fused disconnect switch with branch fusing
- Single-point power and ground wiring connection
- Off-the-shelf microprocessor-based PID auto-tuning controller with To Process and Set Point LED readout
- Low and high process water temperature electronic cut-out switch with LCD display
- Graphic control panel w/status lights

DIMENSIONS: SMCR 5-7.5

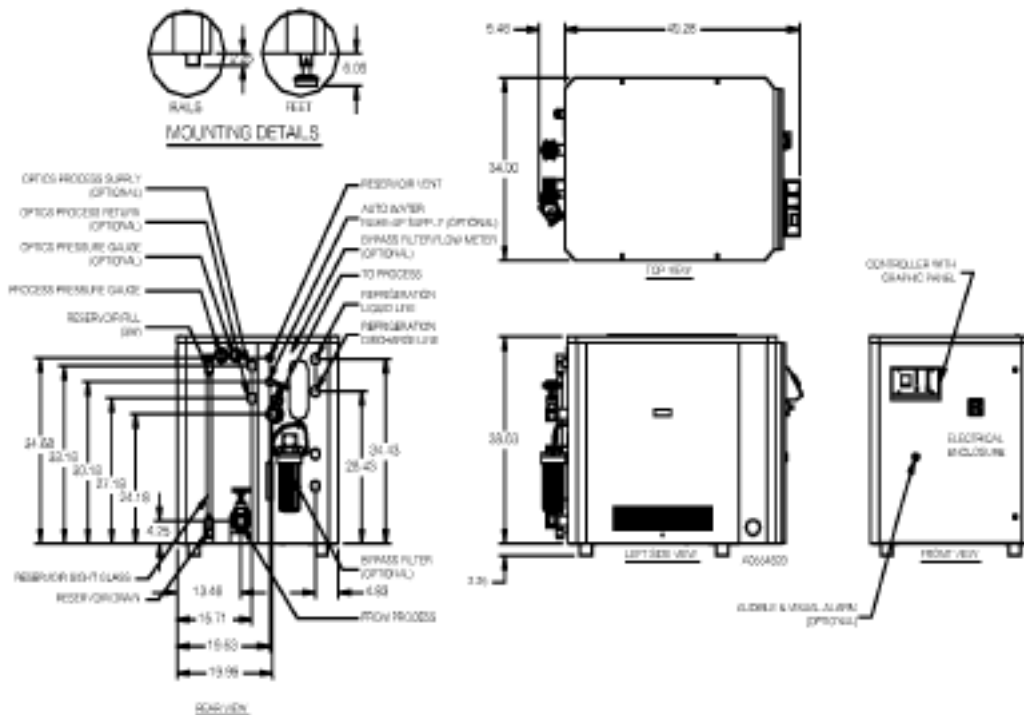

WEIGHTS: SMCR 5-7.5

Model	Dry weight, lbs.	Ship. weight, lbs.	Oper. weight, lbs.
SMCR 5	597	748	930
SMCR 7.5	644	794	977

NOTES: Weights are for standard chiller. Some optional features will increase weight. Operating weight is with a full reservoir tank of water.

SMC SERIES

Remote Air-Cooled Portable Chillers

DIMENSIONS: SMCR 10-40

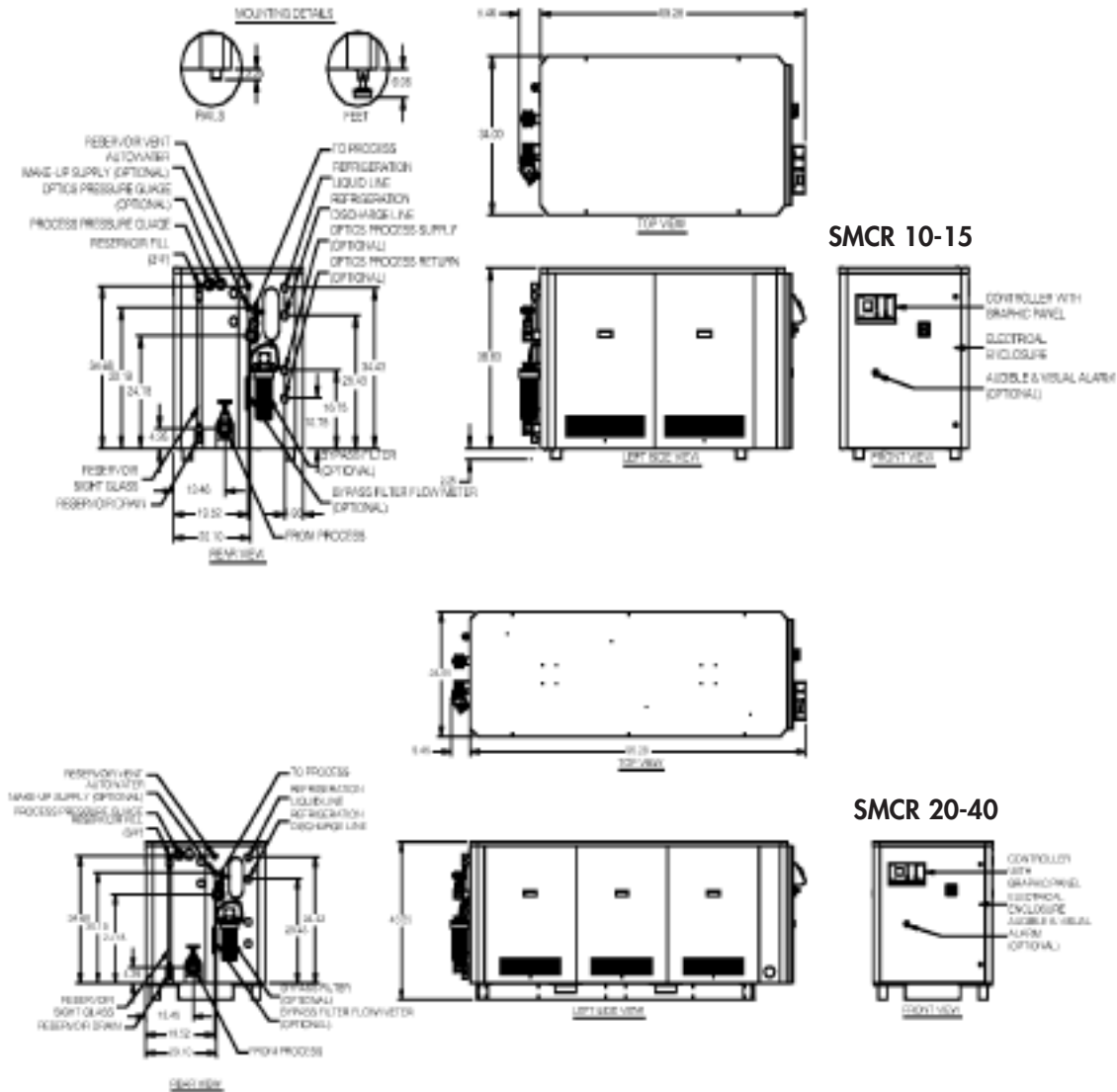

WEIGHTS: SMCR 10-40

Model	Dry weight, lbs.	Ship. weight, lbs.	Oper. weight, lbs.
SMCR 10	827	1052	1159
SMCR 15	870	1095	1202
SMCR 20	1299	1549	1965
SMCR 25	1305	1555	1971
SMCR 30	1607	1857	2273
SMCR 40	2243	2470	2909

NOTES: Weights are for standard chiller. Some optional features will increase weight. Operating weight is with a full reservoir tank of water.

SMC SERIES

Remote Air-Cooled Portable Chillers

REMOTE CONDENSER ASSEMBLY MODELS

End View
SMCR 5 - 10 hp

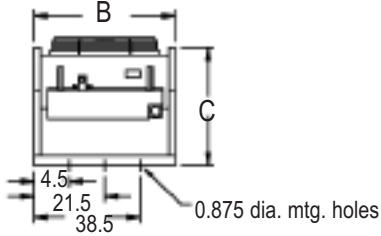

Side View
SMCR 5 - 7.5 hp

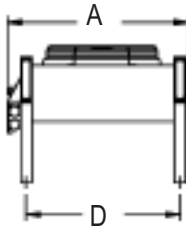

Side View
SMCR 10 hp

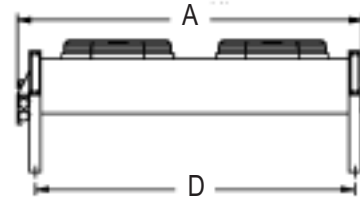

End View
SMCR 15 - 40 hp

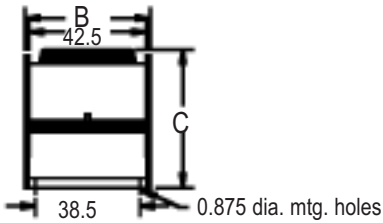

Side View
SMCR 15 - 30 hp

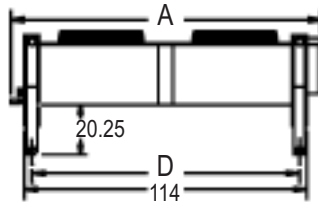

Side View
SMCR 40 hp

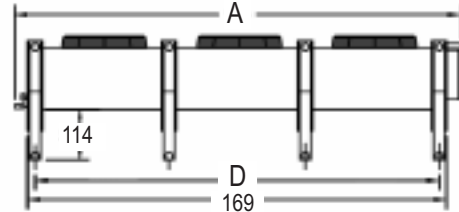

Model	Fans ¹						Remote condenser overall dimensions, in.				Refrigeration ²		
	Each			Totals			Length (A)	Width (B)	Height (C)	Mtg. (D)	Connections		Charge R-22 lbs.
	Dia., in.	Motor, hp (phase)	Amps, 460 V	Fans	Air flow, cfm	Net wt., lbs.					Discharge, ODS, in.	Liquid ODS, in.	
SMCR5	26	0.75, 1 ph	2.4	1	6450	390	49.8	43.0	40.5	40.0	1.125	0.875	9.0
SMCR7.5	26	0.75, 1 ph	2.4	1	6450	390	49.8	43.0	40.5	40.0	1.125	0.875	9.0
SMCR10	26	0.33, 3 ph	3.7	2	12400	520	69.8	43.0	40.5	60.0	(2) 1.125	(2) 0.875	9.5
SMCR15	30	1.5, 3 ph	5.9	2	23000	790	125.0	45.5	50.0	108.0	1.375	1.375	8.0
SMCR20	30	1.5, 3 ph	5.9	2	23000	800	125.0	45.5	50.0	108.0	1.375	1.375	8.0
SMCR25	30	1.5, 3 ph	5.9	2	21900	860	125.0	45.5	50.0	108.0	1.625	1.625	12.0
SMCR30	30	1.5, 3 ph	5.9	2	20700	950	125.0	45.5	50.0	108.0	1.625	1.625	15.0
SMCR40	30	1.5, 3 ph	9.4	3	32900	1,300	180.0	45.5	50.0	163.0	2.125	2.125	19.0

¹ All motors are 1140 rpm. All first fan motors (header side) are 0.75 hp single phase variable speed.

² Refrigeration charge is for remote condenser only.

SMC SERIES

Remote Air-Cooled Portable Chillers

MIN. AND MAX. FLOW RATES

SMC 2				SMC 3.5				SMC 5				SMC 7.5			
Flow		Pressure drop ΔP		Flow		Pressure drop ΔP		Flow		Pressure drop ΔP		Flow		Pressure drop ΔP	
gpm	lpm	psig	kPa	gpm	lpm	psig	kPa	gpm	lpm	psig	kPa	gpm	lpm	psig	kPa
4.06	15.4	3.5	24.1	8.03	30.4	4.0	27.6	10.0	37.9	1.5	10.5	12.0	45.4	2.3	16.1
6.01	22.8	7.0	48.3	10.00	37.9	6.5	44.8	12.0	45.4	2.2	14.8	16.0	60.6	2.9	20.1
8.02	30.4	11.5	79.3	12.00	45.4	10.0	69.	18.0	68.1	4.7	32.1	20.0	75.7	5.0	34.5
10.00	37.9	18.0	124.1	14.00	53.0	13.0	89.6	24.0	90.8	7.3	50.2	24.0	90.8	6.9	47.4
				16.0	60.6	18.0	124.1					28.0	106.0	9.6	65.9
												33.0	124.9	12.7	87.8
SMC 10				SMC 15				SMC 20				SMC 25			
Flow		Pressure drop ΔP		Flow		Pressure drop ΔP		Flow		Pressure drop ΔP		Flow		Pressure drop ΔP	
gpm	lpm	psig	kPa	gpm	lpm	psig	kPa	gpm	lpm	psig	kPa	gpm	lpm	psig	kPa
22.0	83.3	4.7	32.6	30.0	113.6	4.5	31.3	40.0	151.4	4.0	27.6	55.0	208.2	5.5	37.9
30.0	113.6	8.28	57.1	40.0	151.4	7.5	51.7	45.0	170.3	4.0	27.6	58.0	219.5	5.8	40.0
38.0	143.8	12.91	89.0	50.0	189.3	12.4	85.2	50.0	189.3	5.0	34.5	61.0	230.9	6.0	41.4
46.0	174.1	16.77	115.6	60.0	227.1	17.8	122.8	52.0	196.8	6.0	41.4	70.0	264.9	8.5	58.6
50.0	189.3	20.00	137.9	70.0	264.9	24.2	166.6	55.0	208.2	6.5	44.8				
SMC 30				SMC 40											
Flow		Pressure drop ΔP		Flow		Pressure drop ΔP									
gpm	lpm	psig	kPa	gpm	lpm	psig	kPa								
72.0	272.5	6.0	41.1	44.7	169.2	2.0	13.8								
75.0	283.9	6.5	44.8	58.5	221.4	3.4	23.4								
80.0	302.8	8.0	55.2	70.9	268.3	4.9	33.8								
85.0	321.7	9.5	65.5	81.6	308.8	6.3	43.5								
				105.7	400.0	10.3	71.0								

FLOW AND PRESSURE CONSIDERATIONS

Model	Design flow		Design Δ P		Standard pump power		To process pressure		
	gpm	lpm	psig	kPa	hp	kW	psi	kPa	bars
SMCA2	4.6	17.5	4.4	30.4	1	0.746	34.1	235.3	2.4
SMCA3.5	7.9	29.9	4.9	33.7	1	0.746	33.0	227.5	2.3
SMCA/R5	11.6	43.8	2.0	13.7	1	0.746	34.9	240.8	2.4
SMCA/R7.5	15.7	59.6	2.8	19.0	1	0.746	32.7	225.7	2.3
SMCA/R10	23.8	90.1	5.1	35.2	2	1.492	43.4	299.0	3.0
SMCA/R15	34.9	132.1	6.1	41.8	2	1.492	38.0	262.1	2.6
SMCA/R20	46.5	175.9	7.1	49.0	5	3.73	54.0	372.3	3.7
SMCA/R25	57.2	216.4	8.1	55.9	5	3.73	52.0	358.5	3.6
SMCA/R30	70.2	265.6	10.5	72.4	5	3.73	47.5	327.5	3.3
SMCR35	73.5	278.2	5.4	37.2	7.5	5.59	64.0	441.3	4.4
SMCR40	88.6	335.4	8.2	56.5	7.5	5.59	55.0	379.2	3.8
SMCW2	5.1	19.1	5.7	39.1	1	0.746	32.9	226.6	2.3
SMCW3.5	8.6	32.7	6.0	41.2	1	0.746	31.7	218.5	2.2
SMCW5	12.6	47.7	2.3	16.00	1	0.746	34.3	236.2	2.4
SMCW7.5	17.0	64.5	3.1	21.4	1	0.746	32.0	220.3	2.2
SMCW10	25.7	97.4	6.3	43.3	2	1.492	41.4	285.3	2.9
SMCW15	38.1	144.1	7.0	48.1	2	1.492	35.5	244.4	2.4
SMCW20	50.4	190.8	8.8	60.3	5	3.73	52.0	358.5	3.6
SMCW25	61.7	233.7	9.0	62.1	5	3.73	49.0	337.9	3.4
SMCW30	76.2	288.5	10.8	74.1	5	3.73	43.0	296.5	3.0
SMCW40	98.4	372.4	8.2	56.5	7.5	5.59	55.0	379.2	3.8

RECIRCULATION PUMP SPECS

Model	Recirc. power		Flow rate		Δ pressure	
	hp	kW	gpm	lpm	psi	kPa
SMC 5	0.75	0.373	13.0	49.2	2.3	16.0
SMC 7.5	0.75	0.373	17.0	64.3	3.1	21.4
SMC10	0.75	0.595	26.0	98.4	6.3	43.3
SMC15	0.75	0.595	38.0	143.8	7.0	48.0
SMC 20	2.0	1.492	50.0	189.2	8.8	60.3
SMC 25	2.0	1.492	63.0	238.4	9.0	62.0
SMC 30	2.0	1.492	76.0	287.6	10.8	74.1
SMC 35	3.0	2.238	82.0	310.4	5.4	37.2
SMC 40	3.0	2.238	98.0	370.9	8.2	56.5

NOTES: Pressure drop values are valid for single-pump and no-pump SMC Series portable chillers.

Subtract chiller ΔP from pump curve pressure for actual To Process pressure.

Recirculation pump is required for flow rate values exceeding maximums.



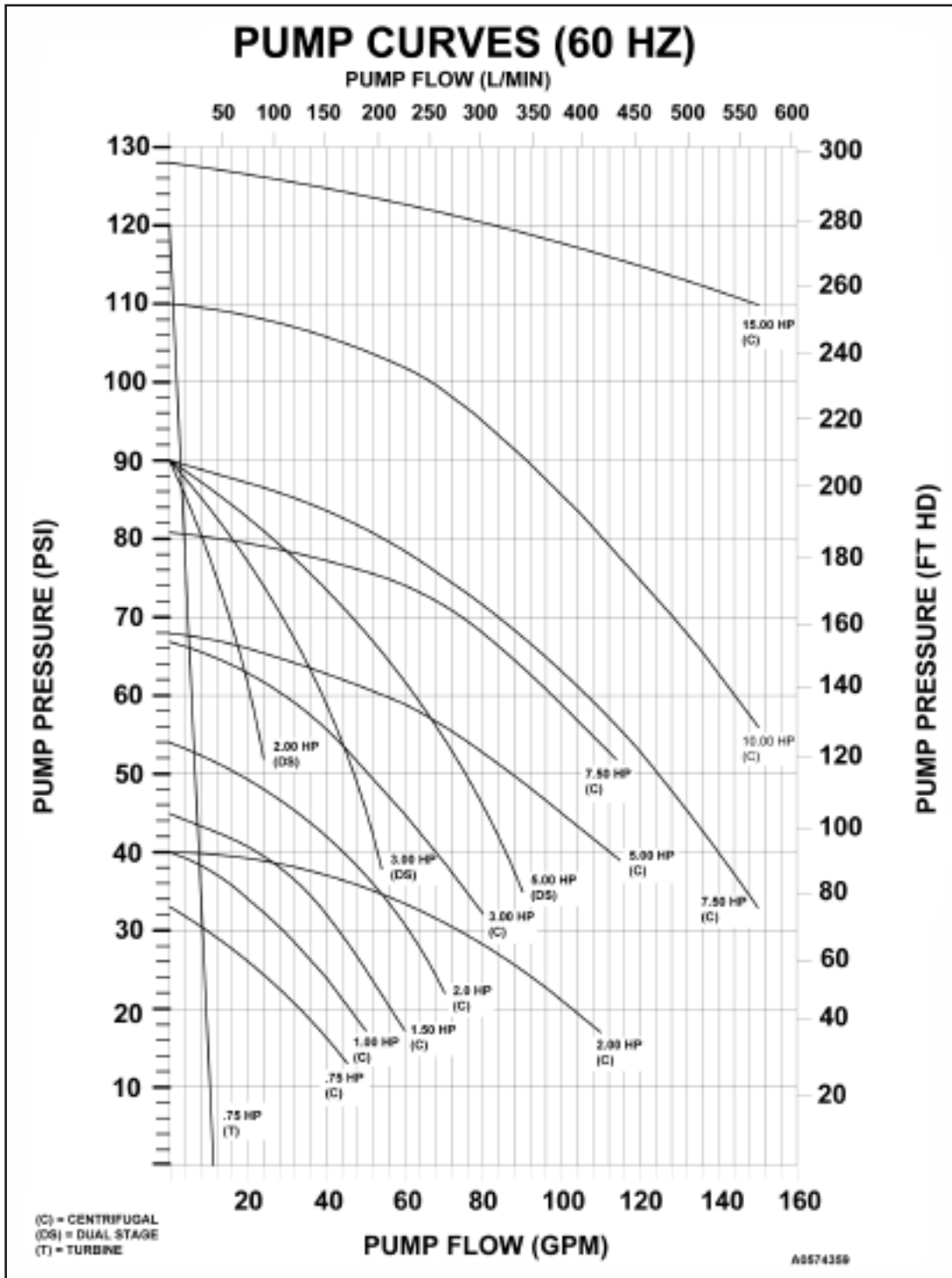

Important! Pump pressure must be corrected for pressure at chiller 'To Process' connection.

SMC SERIES

Pump Curves: 50 Hz

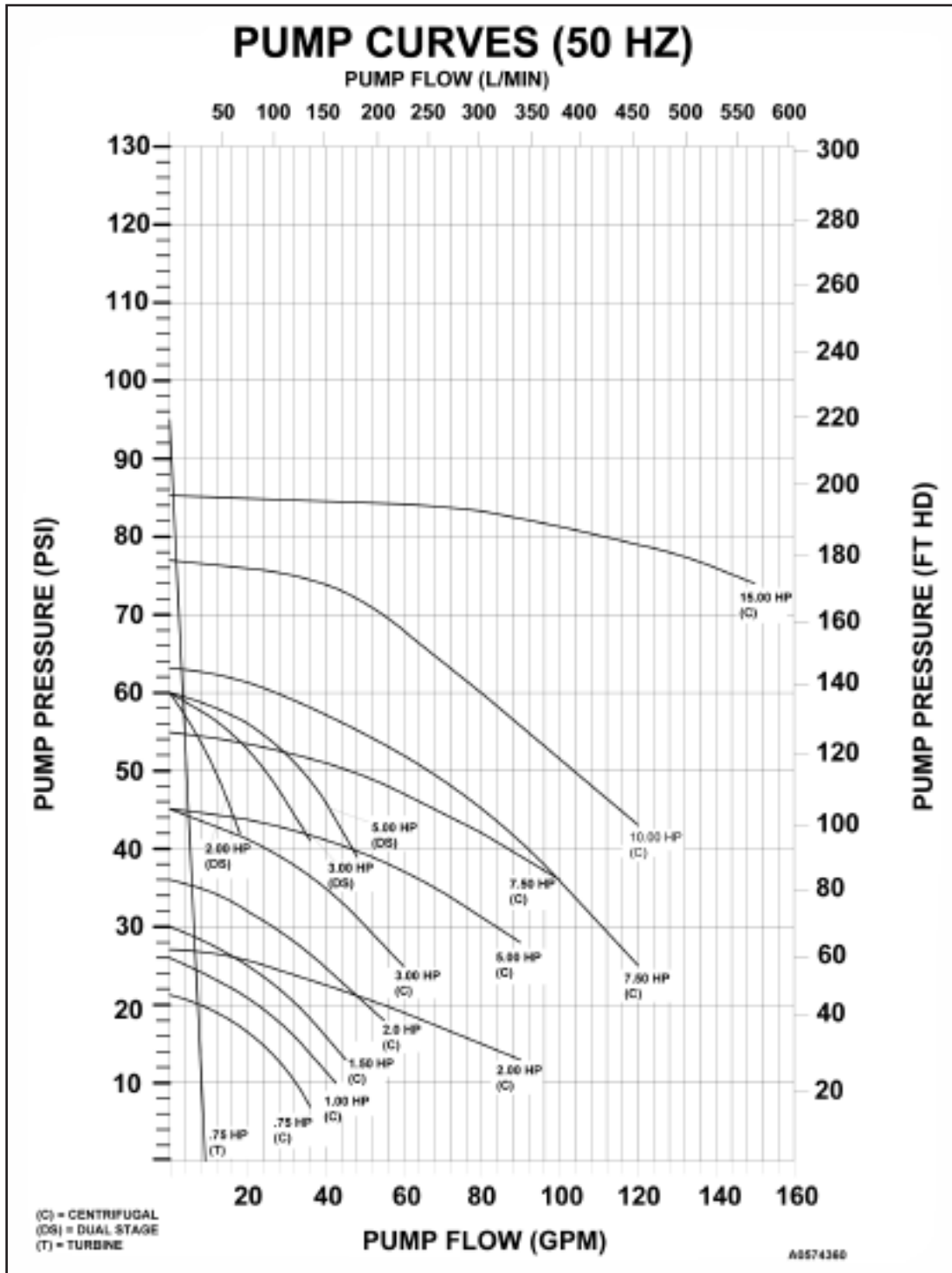

Important! Pump pressure must be corrected for pressure at chiller 'To Process' connection.