



LIGHT DUTY SHREDDER

POWER AND PERFORMANCE FOR TROUBLE-FREE SIZE REDUCTION

The SLS Series light duty single shaft shredder is designed for processing injection and extrusion mold startup purge. It reduces material to approximately 1" to 4" when combined with a Sterling granulator (stacked 2 stage or in-line with conveyors) and output material sizes can range from 1/8" to 1/2". The granulator can average 150% of its stated throughputs without heavy power consumption loads (typically seen when using a granulator alone).

Features

- 12" diameter drum style rotor provides efficient cutting of various process scrap
- Low speed rotor (72 rpm) transmits high cutting torque for tough applications
- The low speed cutting action reduces noise levels
- Standard rotor is fabricated using abrasion-resistant steel for long life in high wear applications
- 4-edge 1.3" (34mm) reversible cutters with bolt-in replaceable knife seat for easy maintenance
- Heavy-duty self aligning outboard mounted bearings that reduce the possibility of material contamination
- Double wall manual feed hopper that can be positioned for feeding through front, back, or side of machine
- Tangential feed hopper for easy ingestion of material without the need of a hydraulic ram



Direct drive shredder style rotor to reduce startup purge and flash to less than 4" particle that can be granulated by a beside the press granulator



Standard hardened rotor with replaceable cutters and cutter seats designed for processing the thicker sections of startup purge and blow molding flash

SLS SERIES



Specifications	
Model	SLS 600+
Feed Opening, in. (mm)	21.7 x 19.3 (550 x 490)
Usable Area of Cutting Chamber, in. (mm)	22.8 x 22.0 (580 x 560)
Feed Height, in. (mm)	69.9 (1775)
Rotor Dia., in. (mm)	12 (310)
Rotor Width, in. (mm)	24 (600)
Rotor Speed (rpm)	72 rpm
No. of Cutters (34mm x 34mm)	26
Drive Capacity, hp (kW)	15 (11)

*The shredder can ingest lumps with diameters up to 15.5" (400mm)

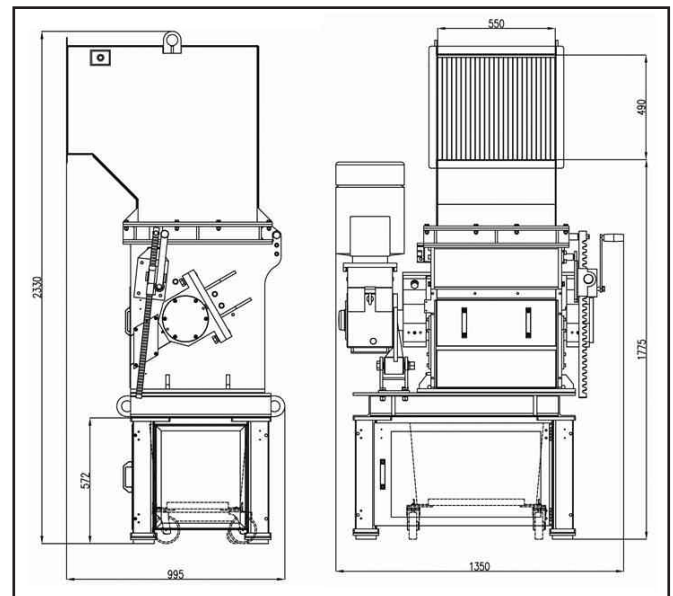

Sterling New Berlin
 2900 S 160th Street
 New Berlin, WI 53151 USA
 Tel: +1 262 641 8610
 Fax: +1 262 641 8653
 www.sterlco.com

Sterling Schaumburg
 1100 E Woodfield Rd #550
 Schaumburg, IL 60173 USA
 Tel: +1 847 273 7700
 Fax: +1 847 273 7804

Sterling Warsaw
 ul.Dziakowa 115
 02-234 Warszawa
 Tel: +48 22 390 9720
 Fax: +48 22 390 9724

Sterling India
 Gat No. 191/1, Sandbhor Complex,
 Mhalunge, Chakan, Tal Khed,
 Dist. Pune 410501, India
 Tel: +91 21 35329112
 Fax: +91 20 40147576

Sterling Suzhou
 109 Xingpu Road SIP
 Suzhou, China 215126
 Tel: +86 512 8717 1919
 Fax: +86 512 8717 1916

