



0.40-9.0 CU. FT.
DRYING HOPPERS

SMALL STAINLESS STEEL DRYING HOPPERS

The SH Series drying hoppers are available in machine-mount and floor-mount configurations. They feature unique mass-flow design, full hopper insulation, and slide gate shut-off. The large access door allows for easy cleanout. These drying hoppers are designed to promote even heat distribution and material mass flow to ensure adequate drying throughout the hopper.

Performance Driven Design Features

- Unique mass flow design
- Stainless steel construction (inside and out)
- Hinged access door (3.0 cu. ft. [85 liter] and larger models) Hinged access door on 1.7 cu. ft. model (50 liter) is optional
- Dual-wall insulated cylinder and cone section
- Material drain spout
- Slide gate on machine mount and floor mount hoppers
- Extended length sight glass on drying hopper door

Available Options

- Small footprint uses minimal floor space
- Floor stand (less casters)
- Handle kit with casters for floor stand (SH 0.40 - SH 9.0 floor-mount models only)
- Portable cart to mount one drying hopper and one dryer
- Cover selections: SSR/SSL vacuum loader, manual fill, or blank
- Gaylord fill stand, including slide gate. 50" (127 cm) clearance
- Adjustable proximity switch mounted on sight glass
- Drain port (standard on machine mount units)



SH SERIES



Drying Hopper	A	B	C	D
SH-0.40	18	11	1.5	25
SH-0.85	25	14	2.5	25
SH-1.7	34	14	2.5	25
SH-3.0	38	22	2.5	25
SH-4.0	44	22	2.5	25
SH-6.0	56	22	2.5	25
SH-9.0	68	22	2.5	25

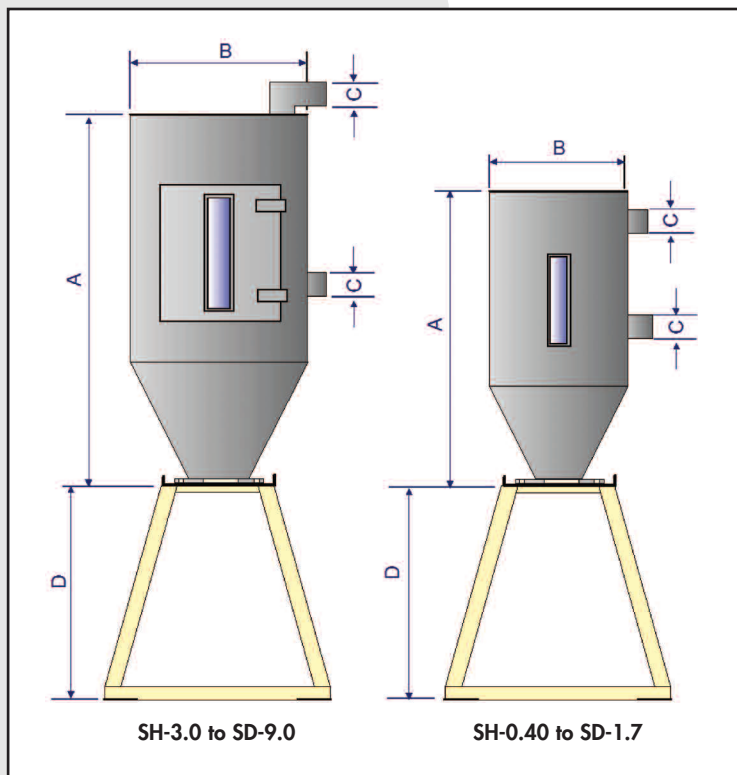

Hopper interior features stainless steel throughout



Sterling New Berlin
 2900 S 160th Street
 New Berlin, WI 53151 USA
 Tel: +1 262 641 8610
 Fax: +1 262 641 8653
www.sterlco.com

Sterling Schaumburg
 1100 E Woodfield Rd #550
 Schaumburg, IL 60173 USA
 Tel: +1 847 273 7700
 Fax: +1 847 273 7804

Sterling Warsaw
 ul.Dziakowa 115
 02-234 Warszawa
 Tel: +48 22 390 9720
 Fax: +48 22 390 9724

Sterling India
 Gat No. 191/1, Sandbhor Complex,
 Mhalunge, Chakan, Tal Khed,
 Dist. Pune 410501, India
 Tel: +91 21 35329112
 Fax: +91 20 40147576

Sterling Suzhou
 109 Xingpu Road SIP
 Suzhou, China 215126
 Tel: +86 512 8717 1919
 Fax: +86 512 8717 1916

