

Floor Mount Large Drying Hoppers

HIGH ENERGY EFFICIENCY FOR OPTIMIZED DRYING

SH Series drying hoppers are for the drying of thermoplastic pellets and regrind, as part of a drying system.

Sterling drying hoppers are designed for continuous 24-hour operation, and meet all European CE requirements.

Sterling drying hoppers are constructed of carbon steel, or stainless steel. Material and air flow have been carefully engineered for optimum drying results at high energy efficiency. The hopper is insulated into the discharge cone, preventing heat loss while serving as effective protection against accidental contact.



Features

- Carbon steel construction
- Extra large access door
- No gaskets
- Long sight glass on door
- Insulated, with extra insulation on cone
- Machine-, floor-, or mezzanine-mount
- Slide gate
- Drain port

Options

- Stainless steel construction
- Level sensors for material level sensing
- Rack and pinion slide gate
- Air operated discharge with material stub, less controls
- Adapter to mount SSR85/170 vacuum receiver
- Drawer magnet

SH SERIES

Floor Mount Large Drying Hoppers

DIMENSIONS

Model	Size, cu. ft. (l)	Weight, lbs. (kg)	A	B	C	D	E	F	G	H	J
SH12	12 (340)	420 (191)	24	28	11	68	3	3	10	9	10 1/8
SH17	17 (481)	595 (270)	24	28	11	88	3	3	10	9	10 1/8
SH23	23 (651)	805 (365)	30	34	11	81	3	3	10	9	10 1/8
SH30	30 (850)	1050 (476)	30	34	11	99	3	3	10	9	10 1/8
SH45	45 (1274)	1575 (714)	40	44	15	100	3	5	16 1/4	12	17 1/8
SH60	60 (1699)	2100 (953)	40	44	15	120	5	5	16 1/4	12	17 1/8
SH75	75 (2124)	2625 (1191)	40	44	36	141	5	5	16 1/4	12	17 1/8
SH90	90 (2549)	3150 (1429)	50	54	23	126	8	5	16 1/4	12	17 1/8
SH135	135 (3823)	4725 (2143)	50	54	52	163	8	5	16 1/4	12	17 1/8
SH180	180 (5097)	6300 (2858)	64	68	63	156	8	5	16 1/4	12	17 1/8
SH240	240 (6796)	8400 (3810)	64	68	92	185	10	5	16 1/4	12	17 1/8
SH300	300 (8495)	10,500 (4763)	74	78	75	186	10	5	16 1/4	12	17 1/8
SH425	425 (12,035)	14,875 (6747)	74	78	114	225	10	5	16 1/4	12	17 1/8

Note: All dimensions are in inches

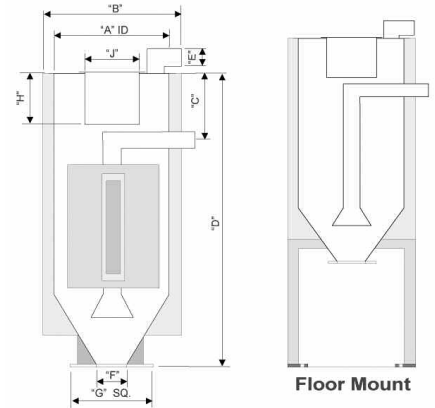

FLOOR STAND DIMENSIONS

Model	A	AA	B	BB	D (Std)	D (Gaylord)	E (Std)	E (Gaylord)
SH12	24	54	28	60	25	52	28	55
SH17	24	54	28	60	25	52	28	55
SH23	34	54	34	60	25	52	28	55
SH30	30	54	34	60	25	52	28	55
SH45	40	54	44	60	25	52	28	55
SH60	40	54	44	60	25	52	28	55
SH75	40	54	44	60	25	52	28	55
SH90	50	54	54	60	25	52	28	55
SH135	50	54	54	60	25	52	28	55
SH180	64	68	68	74	25	52	28	55
SH240	64	68	68	74	25	52	28	55
SH300	74	78	78	84	25	52	28	55
SH425	74	78	78	84	25	52	28	55

Note: All dimensions are in inches

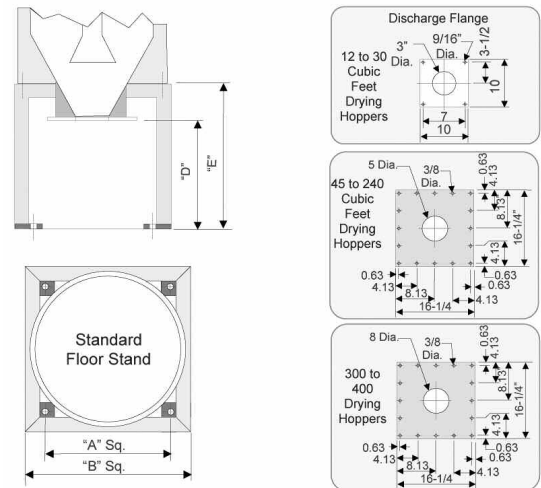

BOLT PLACEMENT

Model	A	B	C	D	E	F	G
SH12	1/4-20	6	11	10-1/8	28	5/8	23
SH17	1/4-20	6	11	10-1/8	28	5/8	23
SH23	1/4-20	6	11	10-1/8	34	5/8	29
SH30	1/4-20	6	11	10-1/8	34	5/8	29
SH45	1/4-20	6	18	17-1/8	44	5/8	39
SH60	1/4-20	8	18	17-1/8	44	5/8	39
SH75	1/4-20	8	18	17-1/8	44	5/8	39
SH90	1/4-20	8	18	17-1/8	54	5/8	49
SH135	1/4-20	8	18	17-1/8	54	5/8	49
SH180	1/4-20	8	18	17-1/8	68	5/8	63
SH240	1/4-20	8	18	17-1/8	68	5/8	63
SH300	1/4-20	8	18	17-1/8	78	5/8	73
SH425	1/4-20	8	18	17-1/8	78	5/8	73

Note: All dimensions are in inches

