

SGR1 SERIES



Single-Chamber Film Grinder

SCRAP HANDLING AND RECLAIM FOR A VARIETY OF PROCESSES

Sterling's SGR1 Series film grinders are designed to handle a wide range of materials and can be equipped with our exclusive feed roll assemblies for automatic feeding of scrap roll stock. SGR1 Series film grinders are used to grind film scrap into small particles of fluff that can be combined with palletized material and fed back into an extruder.



Features

- Frame-mounted control panel complete with all starters, relays, switches, etc. required for proper operation
- Frame-mounted fluff blower
- Heavy-machined plate cutting chamber
- Outboard-mounted bearings with scraper blades
- High shear, scissor cut design
- Four (4) -blade adjustable slant knife rotor, one (1) bed knife; D2 steel
- Reinforced grinder screen
- 460/3/60 supply voltage

Options

- Doctor blade on lower roll to help reduce wrapping
- Exclusive feed roll "undercut" knurl design helps prevent knurl wear
- Heavy-duty hollow shaft gearbox and variable speed drive motor package
- Front door with hinge and quick-release clamp
- Adjustable finger guards
- Assembly hinged with quickrelease clamp for cleaning
- Pneumatic assist provided with Model 20 & Model 30 feed roll assemblies
- Angled feed roll geometry to assist in feeding thick films
- Steep wall grinder chute to advance roll stock and film
- Optional feed roll reversing switch available
- Safety switches on all hinged components

SGR1 SERIES

Single-Chamber Film Grinder

SPECIFICATIONS

Model	Grinder Motor		Fluff Blower Motor		Grinder rate range ¹		Screen Hole Size ²	
	HP	kW	HP	kW	lbs./hr	kg/hr	in. dia.	mm dia.
SGR1-812-20	20	14.92	2.0	1.49	225-275	102-124	0.1875	4.762
SGR1-1218-30	30	22.38	5.0	3.73	350-450	159-204	0.1875	4.762
SGR1-1218-40	40	29.84	5.0	3.73	400-500	181-227	0.1875	4.762
SGR1-1824-75	75	55.95	10.0	7.46	600-1000	272-454	0.3125	7.438

1 Feed rate range is based on 1.0 mil LDPE film scrap; actual rate will vary. Material type and thickness can greatly impact the performance of film grinders. Sterling is not responsible for grinder performance under certain operating conditions with which the equipment is not designed to handle, or if the material type and thickness is not known or specified with the order. It is the responsibility of the salesperson and the customer to inform the factory of the exact scrap film application with confirming orders.

2 Screen hole diameter in mm is approximate. Screen size required may vary depending upon the material type and thickness.

TYPICAL SGR1 SERIES FILM GRINDER SYSTEM

Note: The following drawing is shown with the optional feed roll assembly for scrap roll feeding.

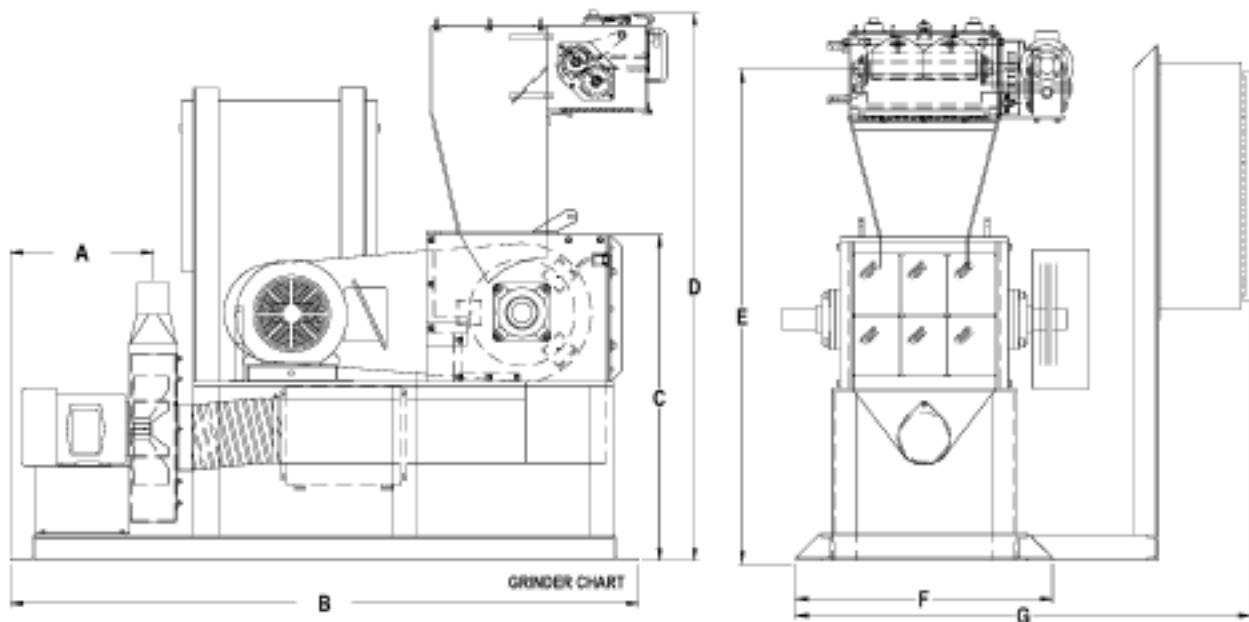

Optional relief head (edge trim exhauster) not shown

DIMENSIONS

Model	A	B	C	D	E	F	G
	in. (cm)	in. (cm)	in. (cm)	in. (cm)	in. (cm)	in. (cm)	in. (cm)
812	20 (51)	69 (176)	33 (83)	45 (113)	60 (151)	24 (61)	51 (129)
1218	17.5 (45)	77 (196)	40 (102)	67 (171)	61 (155)	32 (80)	56 (145)
1824	Consult factory for dimensions						