

SGBD SERIES

PRODUCT
AVAILABLE ONLINE



Gravimetric Batch Blender

ACCURATE, HOMOGENOUS BLENDING FOR FREE FLOWING MATERIALS

All SGBD Series batch blenders feature precision 0.02% span accurate cantilever load cells and exclusive, heavy-duty diamond design slide gate metering assemblies, which provide for 1/2% to 100% recipe range for free-flowing pellets. The adjustable slide gate stroke limiters provide for accurate metering of minor ingredients. The mixer section is designed for efficiency and blend homogeneity. All metering, weighing, and blending components are constructed of stainless steel.



Features

- Mitsubishi PLC control system with touch-screen interface and 30' or 50' cable, serial printer port, (optional Ethernet port available), 50 recipe storage book, alarm light, audible alarm, and 3 modes of recipe entry
- Powder coated, mild steel material supply hoppers with machined polycarbonate access doors (stainless steel on SGBD-150)
- Heavy-duty diamond metering gate assemblies (except on SGBD-150)
- Square gate supplied on component #3 regrind on SGBD-500 and SGBD-900 and components #1 and #3 on SGBD-4000 and SGBD-6000
- Adjustable stroke limiters for all ingredients (not available with SGBD-150)
- Precision 0.02% span accurate cantilever load cell weigh system
- Removable, stainless steel weigh hopper
- Efficient mix chamber design
- Removable stainless steel mixer agitator
- Removable stainless steel mixer drawer assembly, bolted in place on SGBD-4000 and SGBD-6000 models. Integrated stainless steel mixer bowl on SGBD-150
- Interlocked safety system shuts off air and electricity if mix chamber is opened
- "H" models include two large hoppers with diamond gates and two removable hoppers with vertical gates
- Supply hopper lids for Sterling SSK receivers and loaders or blank lids. Lids may also be cut for non-Sterling receivers at no additional charge, provided detailed drawings are received with order
- 5th and 6th components include horizontal gates
- 7th and 8th components include additive feeders
- 115/1/50 or 60 supply voltage

Options

- Low-level solid-state proximity sensor for each supply hopper (alarm functions and indicators are included in the PLC controller)
- Drain tube with slide gate in supply hopper
- Regrind Auger Metering (RAM) assembly with agitated straight wall hopper, including interlocked access door (not available with SGBD-150 or 500) – add "R" to the end of the model number
- Stainless steel supply hoppers (Allow additional lead time)
- Additional drop-in hoppers with blank hand fill lids (SGBD-150, SGBD-500, and SGBD-900 only)
- Blender floor stands with slide gates
- Vacuum take-off boxes mounted below surge hopper under floor stands
- Aluminum spool (premium mounting flange) with drain port (8" x 8" square)
- Low-profile drawer-magnet (3 bar)
- Customer-specified (special) mounting hole pattern – drawing required with order
- Mezzanine, drumfill, or gaylor fill blender stands

Note: Compressed air loaders cannot be used to load SGBD-150

SGBD SERIES

Gravimetric Batch Blender

SPECIFICATIONS

	SGBD-150	SGBD-500	SGBD-900	SGBD-2500	SGBD-4000	SGBD-6000
Max. Blending Rate, lbs./hr (kg/hr) ³	150 (68)	500 (227)	900 (410)	2500 (1135)	4000 (1815)	6000 (2725)
# of materials to be blended	2-4	2-6	2-8			
Slide Gate Size, Majors, in. (mm)	2.0 (50)	2.0 (50)		2.5 (63)	3.0 (76)	
Slide Gate Size, Minors, in. (mm)	1.5 (38)	1.5 (38)		2.0 (50)	3.0 (76)	
Supply Hopper Capacity, Majors, cu. ft. (l) ⁴	0.7 (20)	1.4 (40)		3.0 (85)	7.5 (212)	
Supply Hopper Capacity, Minors, cu. ft. (l) ⁴	0.2 (5)	1.0 (28)		2.7 (77)	6.0 (170)	
Weigh hopper cap. cu. ft. (l)	0.07 (20)	0.18 (50)	0.38 (11)	0.82 (23)	1.23 (34)	2.17 (61)
Typical batch size, lbs. (kg)	1.5 (0.7)	4 (1.8)	8 (3.6)	25 (11.3)	35 (15.8)	45 (20.4)
Mixer cap., cu. ft. (l)	0.18 (5)	0.25 (7)	0.56 (16)	1.1 (31)	2.72 (77)	
Mixer motor size, HP (kW)	1/8 (0.09)	1/6 (0.124)		1/2 (0.373)		
Mixer rpm	42	21		22		
Load cell capacity, kg	1 @ 5 kg	2 @ 3 kg	2 @ 5 kg	2 @ 10 kg	2 @ 15 kg	2 @ 20 kg
Discharge opening, in. (mm)	2.5 (63)	3.0 (76.2)		4.0 (102)		
Machine weight, lbs. (kg)	250 (115)	375 (170)	450 (205)	650 (295)	1100 (500)	
Shipping weight, lbs. (kg)	350 (160)	425 (190)	550 (250)	800 (360)	1300 (590)	
Height, in. (mm)	34.5 (875)	51.5 (1308)	56.5 (1435)	69.5 (1765)	85.5 (2172)	89.5 (2172)
Width, in. (mm)	26.0 (650)	37.5 (952)	37.0 (940)	45.5 (1156)	57.5 (1461)	
Depth, in. (mm)	22.0 (560)	37.0 (940)	40.0 (1016)	46.5 (1181)	57.0 (1448)	

- 1 SGBD blender models with "H" designation include two removable hoppers with integral gates
- 2 SGBD blender models with 7 or 8 components include additive feeders for the 7th and 8th component metering and A-B 10" color touch-screen
- 3 See below for important rate information concerning each model's maximum blending rate
- 4 Hopper capacity measured excludes straight wall section and is based on vacuum receiver use. Approximate value.
- 5 Compressed air loaders cannot be used to load SGBD-150 blenders

IMPORTANT INFORMATION CONCERNING MAX. BLENDING RATE LISTED

Standard maximum blending rate is based on a 3-component blend running 80% virgin, 18% regrind (free-flowing) and 2% pelletized color. Additional components reduce max rate by approximately 20% each.

Recipes with more than 50% regrind will significantly reduce the throughput and minor ingredient accuracy of the blender.

Rates are based on dry, free-flowing virgin pellets with a bulk density of 35 lbs./cu. ft. Rates will vary as a result of the number of blender components, the materials, and the recipe(s) used. Consult the factory for guaranteed rates.

Material samples are required for testing prior to shipment for guaranteed rates. Consult the Sterling Sales Department for shipping instructions and for the amounts of each material to send for testing. A test request form must be submitted, and typical amounts of material required for small blenders are 50 lbs. for major ingredients and 10 lbs. for minor ingredients.

OPTIONAL BLENDER STANDS

Heavy-duty blender stands feature heavy-duty cast aluminum pneumatic slide gate and valve. BD-150 and 500 models should use 30" wide stands; larger blenders should use 56" wide stands.

Regular-Duty floor stands are also available with regular-duty pneumatic slide gate, controls, and 2.0 or 3.5 cu.ft. surge hopper.

Both styles of stands are available in drum fill, gaylord fill, and floor stand configurations. Light-duty casters are available (Not for use on 56" wide heavy-duty stands).

Integrated MTO style take-off tubes for use with 2.0 and 3.5 cu. ft. surge hoppers. Available in 1.5", 2.0", 2.5", 3.0", and 3.5" diameters.

Cast aluminum pneumatic slide gate with controls is required to ensure homogenous mixing prior to discharge, particularly at startup for customer-supplied stands or other special configurations.

Square 10" mounting flange provided for additional take-off compartment

ELECTRICAL OPTIONS

- External audible and visual alarm for remote mounting
- Allen-Bradley PanelView 1000 (10" color touch-screen) in lieu of handheld pendant
- Ethernet module for remote communication
- 220/1/50 or 60 operation (includes CE compliance) - 24 volt controls and 220 volt mixer motor
- A3 communication software for unlimited number of new PLC controlled blenders

SGBD SERIES

Gravimetric Batch Blender

INTEGRATED BLENDING CONTROL SYSTEM OFF-THE-SHELF CONTROL WITH PROVEN RELIABILITY USER-FRIENDLY, MENU-DRIVEN INTERFACE

Sterling's new Mitsubishi PLC-based blender controller provides state-of-the-art process control at your fingertips. Operator-friendly controls simplify operation, store up to 50 recipes and provide unmatched metering accuracy for up to six ingredients, especially below 2%. The operator pendant touch screen interface displays user-friendly, menu-driven interface screens for complete control and monitoring of any batch blending operation. An optional Ethernet port is available.

FEATURES

- Patented Control System
- Touch-screen interface in a remote-mount Pendant enclosure
- Two screens allow total control and monitoring of the blending process
- Constant display of actual material used
- Load cell signal conditioning technology improves reliability and is unaffected by electrical noise
- Redesigned pneumatic and electrical systems improve metering accuracy and blender rate
- Electrical panel meets applicable specifications, with 220 volt operation and CE declaration available
- Integral alarm light and horn indicates material feed problems
- Ethernet module available for off-line monitoring, control, and remote troubleshooting
- Three types of recipe entry formats are available to the operator:
 - Quickset mode meters color and additives as a percentage of the virgin material (most common in injection molding)
 - "Percentage" mode meters all ingredients as a percentage of the overall batch (most common in extrusion and blow molding)
 - "Parts" mode allows for ration recipe entry (e.g. 50:1)



- Programmable entry screens for all three recipe modes (up to six components)
- Real time display of process rate and material usage of each ingredient

SGBD SERIES

Gravimetric Batch Blender

DIMENSIONS

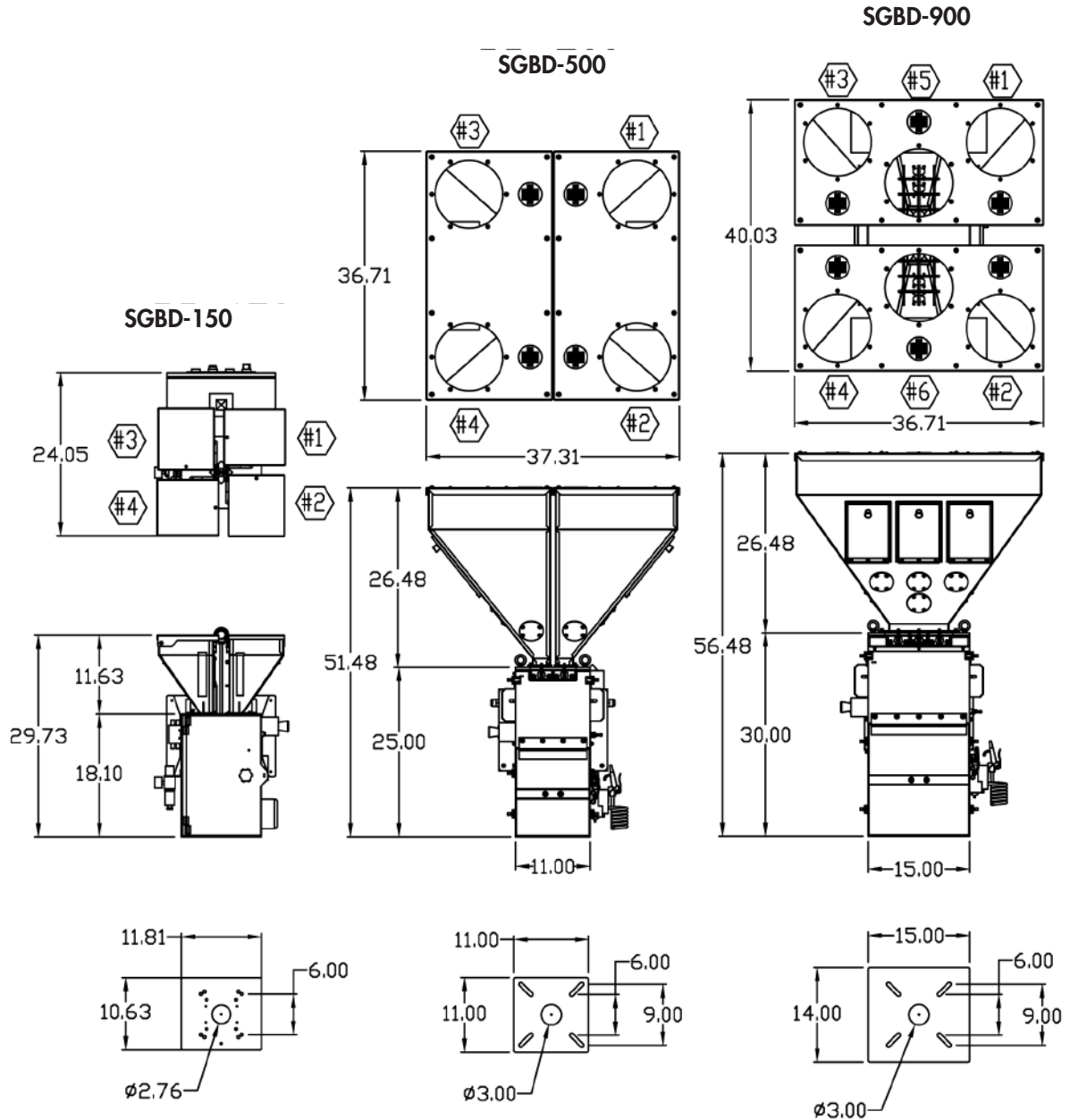

SGBD SERIES



Gravimetric Batch Blender

DIMENSIONS

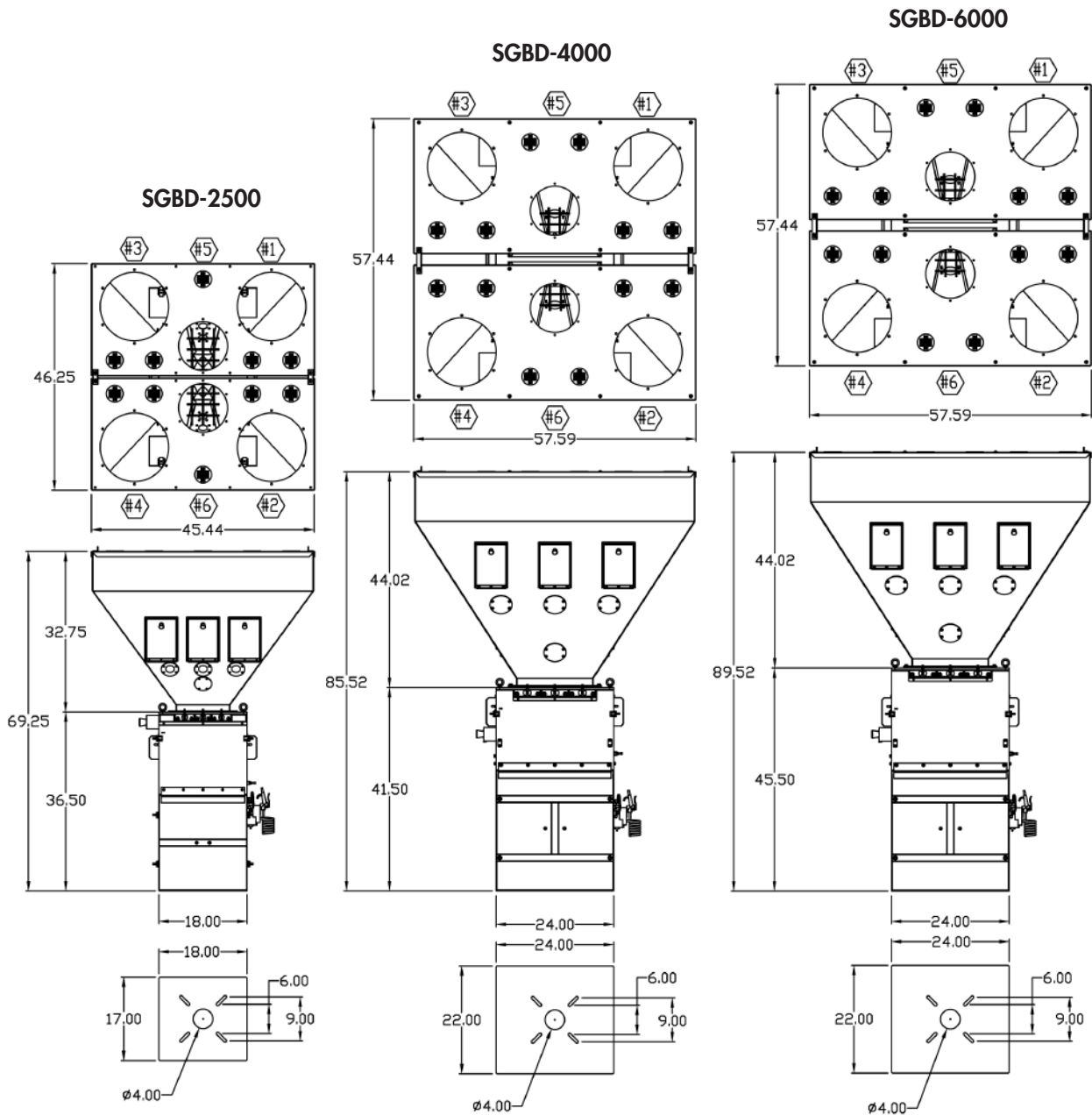

SGBD SERIES

Gravimetric Batch Blender

DIMENSIONS

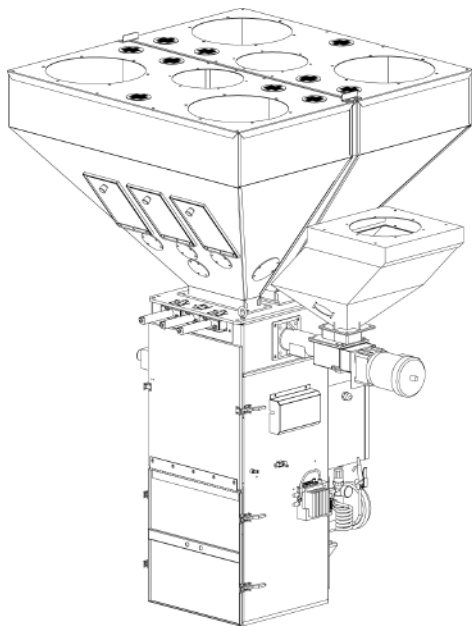

SGBD-2500-7F
Includes:
6 Slidegates, 1 Additive Feeder

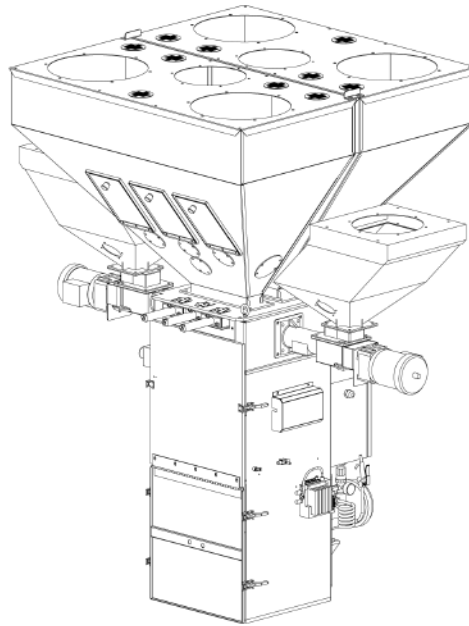

SGBD-2500-8FF
Includes:
6 Slidegates, 2 Additive Feeders

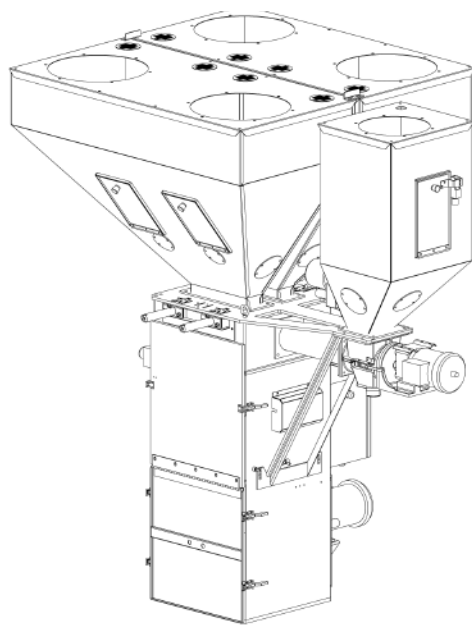

SGBD-2500-5R
Includes:
4 Slidegates, 1 R.A.M. Hopper

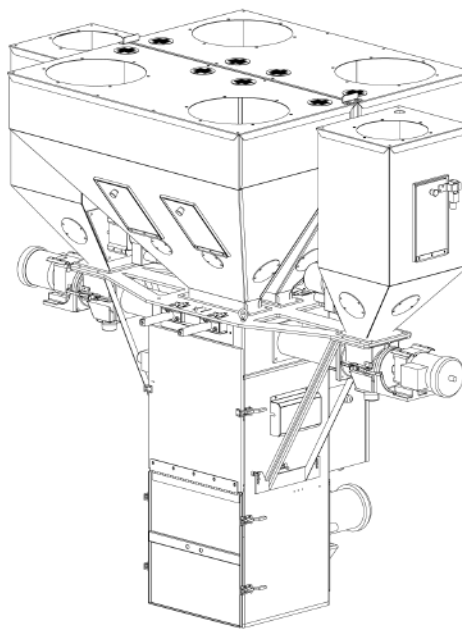

SGBD-2500-6RR
Includes:
4 Slidegates, 2 R.A.M. Hoppers

SGBD SERIES



Gravimetric Batch Blender

COVER LAYOUT SPECIFICATIONS

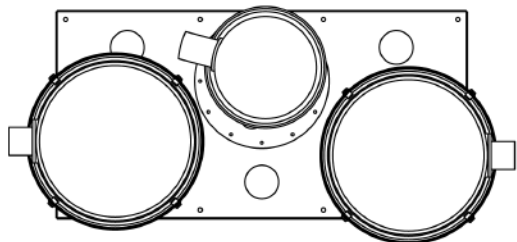

SGBD-500/900
SSX-16, QTY 2
SSX-04, QTY 1

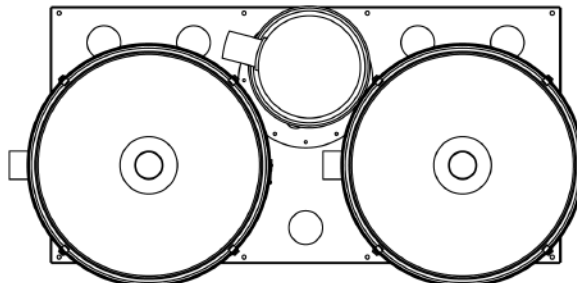

SGBD-2500
SSX-60, QTY 2
SSX-04, QTY 1

SGBD-150-4M
SSX-16, QTY 2
SSX-04, QTY 2

SGBD-150-4H
SSX-16, QTY 2

SGBD-150-4S
MANUAL FILL ONLY

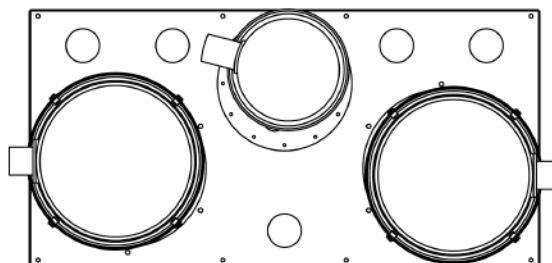

SGBD-2500
SSX-16, QTY 2
SSX-04, QTY 1
2.0CU.FT RAM HOPPER
SRX-16

MAXIMUM LOADER DIAMETER
SSX-30/60: 24"DIA
SSX-08/16: 16"DIA
SSX-01/02/04: 11"DIA

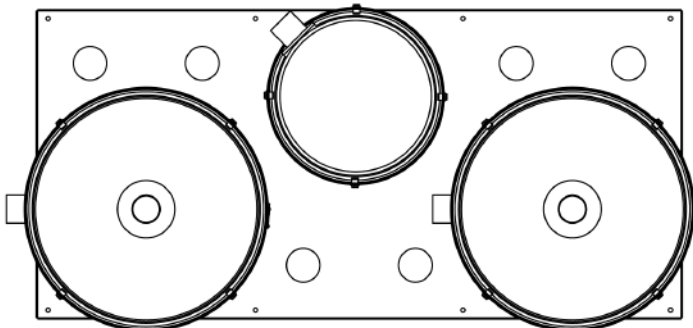

SGBD-4000/6000
SSX-60, QTY 2
SSX-16, QTY 1

7.0 CU.FT RAM HOPPER
SRX-60

SGBD SERIES

Gravimetric Batch Blender

NOTES:

