

TOTAL CONTROL AND MONITORING OF THE BLENDING PROCESS

The SGA Series gravimetric batch blending system features precision auger metering of up to 6 ingredients. They should be used if more than one regrind is required, or when difficult and hard-to-meter materials will be used.

Each SGA blender features machined metering augers, precision load cells, cast aluminum feed auger assemblies and heavy-duty industrial design. The SGA Series offers superior batch control and reliable feeding of difficult materials.



Features

- Mitsubishi PLC-based control system with Panel View touch-screen interface and 50' cable
- Spun material supply hoppers
- Precision auger feeding of all materials with constant speed AC gearmotor (variable speed DC optional)
- "HC" mixer design promotes homogeneity (012 thru 060 models)
- Standard mixer on 002 model
- Precision 1/10% span-accurate offset cantilever load cell
- Convenient compressed air clean-out hose with blowoff tool included
- Machine-mount standard; optional aluminum spool mounting flange with drain port is available
- Drain tube below each feeder housing – for quick drain of material supply hoppers
- Target versus actual set point verification
- English or metric display
- Safety-interlocked access that shuts off both air supply and electricity if blender is opened
- Alarm output (24 VDC)
- Three (3) types or recipe entry procedures available to user: Percentage recipe entry. Ingredients metered as a percentage of the batch. 6-component "EZ" mode recipe entry. Color and additives metered as a percentage of the virgin. "Parts" mode ratio recipe entry (i. e. 500:1)
- Hopper lids arranged for Sterling receivers and loaders (Standard cutout for non-Sterling loaders at no charge if drawings are provided.)
- 115/1/50 or 60 supply voltage

Options

- 12" high extension for major ingredient hoppers
- SCR variable-speed DC drive motor in lieu of standard constant speed AC motor
- Material shutoff slide gates above feeder housing
- Mezzanine, drum-fill or gaylord-fill blender stands
- Stainless steel material supply hoppers
- Agitated straight wall regrind hopper with gear motor (not available on SGA-002)
- Powder feeder for most powder additives, including calcium carbonate, sodium bicarbonate, etc.
- Low-level solid-state proximity sensor for each supply hopper (alarm functions and indicators are included in the PLC Controller)
- Low-profile drawer magnet (3 bar)
- Standard mixer in lieu of HC style mixer
- Premium aluminum spool mounting flange with drain port, 8" x 8" square
- Clean-out doors in spun material supply hoppers, including safety grate or lock-out safety switch
- Customer-specified (special) mounting hole pattern (drawing required with order)
- Vacuum take-off boxes mounted below surge hopper under floor stands

SGA SERIES

Gravimetric Batch Blender

SPECIFICATIONS

	SGA-002	SGA-012	SGA-060
Max blending rate, lbs./hr (kg/hr)	100 (45)	400 (180)	3000 (1360)
Number of materials blended	2-4	2-6	2-6
Supply hopper cap., cu. ft. (l)	0.2 (5)	0.9 (25)	2.0 (56)
Weigh hopper cap. cu. ft. (l)	0.10 (2.8)	0.17 (4.8)	1.4 (39)
Typical batch size, lbs. (kg)	3 (1.4)	5 (2.2)	30 (13)
Mixer capacity, lbs. (kg)	6 (2.7)	40 (18)	75 (34)
Mixer motor size, HP (kW)	1/6 (0.125)	0.5 (0.373)	1 (0.746)
Load cell capacity, lbs (kg)	2 @ 4.4 (2)	1 @ 22 (10)	1 @ 66 (30)
Material discharge, in. (mm) dia.	3 (76)	3 (76)	4 (101)
Machine weight, lbs. (kg)	145 (66)	400 (182)	800 (364)
Shipping weight, lbs. (kg)	200 (91)	600 (273)	1000 (455)

IMPORTANT INFORMATION CONCERNING MAX. BLENDING RATE LISTED

The standard blender's maximum blending rate (capacity) shown above is based on a 3-component blend running the following standard recipe:

- 80% virgin, 18% regrind (free-flowing) or second virgin, 2% color.
- Recipes with a high percentage of regrind, i.e. more than 50%, will significantly reduce the maximum throughput of the blender as well as the accuracy of the minor ingredients. Consult the factory for acceptable minimum and maximum recipes when regrinds will be used at more than 30%.
- Rates and capacities are based on use with free-flowing virgin pellets having a bulk density of 35 lbs./ft³. Bulk density of materials, particularly regrinds, can greatly impact blender performance and output rate.
- Throughput rates will vary as a result of number of blender components, the materials, and the recipe(s) used.
- All materials must be free-flowing and dry.
- Material samples are required for testing prior to shipment for guaranteed rates. Consult the Sterling Sales Department for shipping instructions and for the amounts of each material to send for testing. Typical amounts required are 300 lb. for major ingredients and 30 lb. for minor ingredients.
- 2-component blend

OPTIONAL BLENDER STANDS

Mezzanine-mount, drum-fill and gaylord-fill blender stands are available with pneumatic slide gate and controls. The mezzanine-mount stand is 14" high with a 4" OD tube stub for gravity feed. The drum-fill stand is 42" high, and the gaylord-fill stand is 56" high. Off-line floor stands are supplied with pneumatic slide gate, with either 2.0 cu. ft. or 3.5 cu. ft. surge hopper (vacuum take-off box not included).

Integrated MTO-style take-off tubes for use with 2.0 and 3.5 cu. ft. Surge hoppers available in 1.5, 2.0, 2.5, 3.0, 3.5 dia. sizes. 10" square mounting flange provided for additional take-off compartment mounting.

A pneumatic slide gate below the mixer with controls is required for off-line floor mount, or for use with customer-supplied stand or special configurations.

ELECTRICAL OPTIONS

- PanelView 1000 (10" color touch-screen) in lieu of hand-held pendant
- Ethernet module for remote communication
- A3 communication software for unlimited number of new PLC-controlled blenders
- 220 V operation (includes CE compliance) 24 volt controls and 220 V mixer motor

SGA SERIES



Gravimetric Batch Blender

SGA SERIES STANDARD INGREDIENT RECIPE RANGES - CONSULT FACTORY FOR OTHERS

Model	Auger Metering Ranges in Percentage - select one per ingredient (component)						
All models	1/2 to 2-1/2%	1 to 5%	2 to 10%	5 to 25%	10 to 50%	25 to 75%	50 to 100%

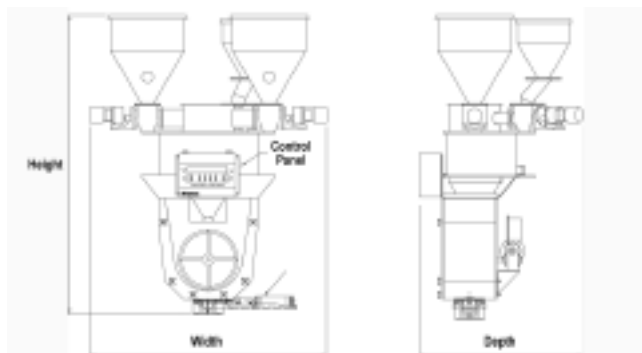

SGA SERIES DIMENSIONS

Model	Height, in. (mm)	Width, in. (mm)	Depth, in. (mm)
SGA-002	38 (965)	58 (1473)	64 (1628)
SGA-012	31 (787)	33 (838)	40 (1016)
SGA-060	33 (838)	46 (1168)	77 (1956)

SGA SERIES

Gravimetric Batch Blender

NOTES:

