



GRAVIMETRIC AUGER BLENDER

BATCH GRAVIMETRIC BLENDERS FOR MOST FREE-FLOWING MATERIALS

The SGA Series gravimetric batch blending system features precision auger metering of all ingredients and can be used for regrind, powder and difficult or hard-to-meter materials.

Key in a recipe and start the unit. Operating parameters are preset. When the level in the mixer drops below the level switch, the weigh hopper will zero. Each ingredient is then accurately metered and weighed. When the weighed batch is complete, all ingredients are discharged into the mixer.

Features

- Easy material clean-out and changeover
- Precision 1/10% of span offset cantilevered load cells
- Cast aluminum feed auger assemblies with stainless steel augers
- Spun material supply hoppers with sight-glass
- "HC" style mixer with removable polycarbonate door
- Adjustable mixing time

Advantages

- Superior batch control up to 1/10 of 1% accuracy for each blended component
- Consistent feeding of difficult materials



SGA-012
Gravimetric
Batch Blender



Integrated Blending Control System

Sterling's new Mitsubishi PLC-based blender controller provides state-of-the-art process control at your fingertips. Operator-friendly controls simplify operation, store up to 50 recipes and provide unmatched metering accuracy for up to six ingredients, especially below 1%. The touch-screen interface displays user-friendly, menu-driven interface screens for complete control and monitoring of any batch blending operation. A serial printer port and an optional Ethernet port are available.

Features

- Touch-screen interface in a remote-mount enclosure
- Two screens allow total control and monitoring of the blending process
- Display of actual material used



Programmable entry screens for all three recipe modes (up to six components)

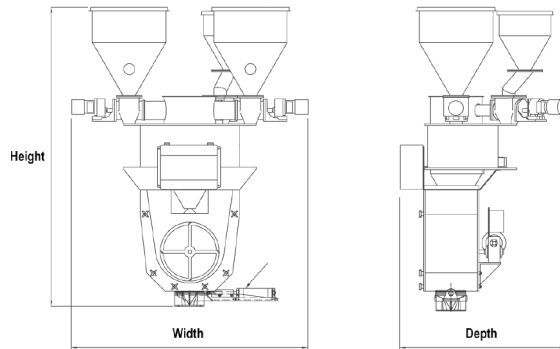

Model	Max. Rate lbs/hr	Max. Rate kgs/hr	Width	Depth	Height
SGA-002	100	45	38"	31"	33"
SGA-012	400	180	58"	33"	46"
SGA-060	3000	1360	64"	40"	77"



Sterling New Berlin
 2900 S 160th Street
 New Berlin, WI 53151 USA
 Tel: +1 262 641 8610
 Fax: +1 262 641 8653
www.sterlco.com

Sterling Schaumburg
 1100 E Woodfield Rd #550
 Schaumburg, IL 60173 USA
 Tel: +1 847 273 7700
 Fax: +1 847 273 7804

Sterling India
 Gat No. 191/1, Sandbhor Complex,
 Mhalunge, Chakan, Tal Khed,
 Dist. Pune 410501, India
 Tel: +91 21 35329112
 Fax: +91 20 40147576

Sterling Warsaw
 ul.Dziakowa 115
 02-234 Warszawa
 Tel: +48 22 390 9720
 Fax: +48 22 390 9724

Sterling Suzhou
 109 Xingpu Road SIP
 Suzhou, China 215126
 Tel: +86 512 8717 1919
 Fax: +86 512 8717 1916

