

RECLAMATION AND RECYCLING MADE EASY

Sterling Single Shaft Shredders are designed for processing plastic waste for reclamation and recycling, large extruder purgings, large reject parts, trim scraps, baled or loose film, synthetic fiber, wood processing scrap, medical waste, cardboard, paper and carpet.

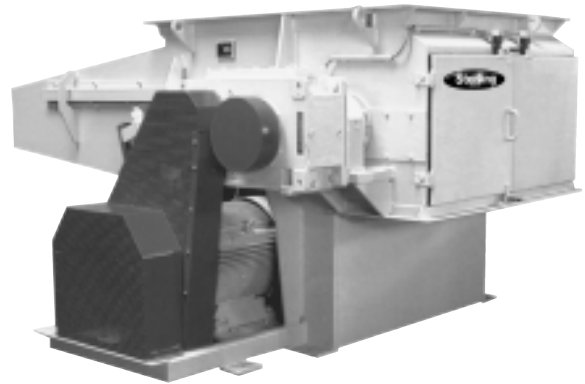

Features

- Optional control brands
- Quick disconnect and quick clean screens
- Application specific programming and control integration
- Multiple rotor configurations
- Special purpose screens
- Critical-duty drivetrain
- High speed ram
- Wear-resistant cutting chamber
- Turnkey installation with custom conveyor systems engineering and material handling
- Low speed/high torque design
- Easy accessibility
- Tramp metal protection
- Touch pad monitoring and control
- Low RPM/low noise
- Large infeed hopper
- Precision hydraulic "process ram"
- 4-way, indexable cutting inserts
- High output "torsion point" cutting rotor
- Severe-duty construction with rugged hydraulics
- 0.015" knife gap and easy-access screen
- Stress-free frame
- Lifetime limited warranty on cutting rotor
- Oversized drivetrain
- Heavy outboard spherical roller bearings
- Fluid "turbocoupling"
- PLC control panel
- ISO 9001 manufactured

Options

- Optional control brands
- Quick disconnect and quick clean screens
- Application specific programming and control integration
- Multiple rotor configurations
- Special purpose screens
- Critical-duty drivetrain
- High speed ram
- Wear-resistant cutting chamber
- Turnkey installation with custom conveyor systems engineering and material handling
- Large infeed hopper
- Precision hydraulic "process ram"
- 4-way, indexable cutting inserts
- High output "torsion point" cutting rotor
- Severe-duty construction with rugged hydraulics
- 0.015" knife gap and easy-access screen
- Stress-free frame
- Lifetime limited warranty on cutting rotor
- Oversized drivetrain

SG SERIES

Single Shaft Shredders

SPECIFICATIONS

Chamber size	Infeed opening, in.	Available HP												
		20	25	30	40	50	60	75	100	125	150	200	225	250
24	24 x 14	X												
32	32 x 40	X		X										
42	42 x 48		X	X	X	X								
52	52 x 68				X	X	X	X	X	X				
62	63 x 80							X	X	X				
78	78 x 87										X	X		
98	98 x 120										X	X	X	X

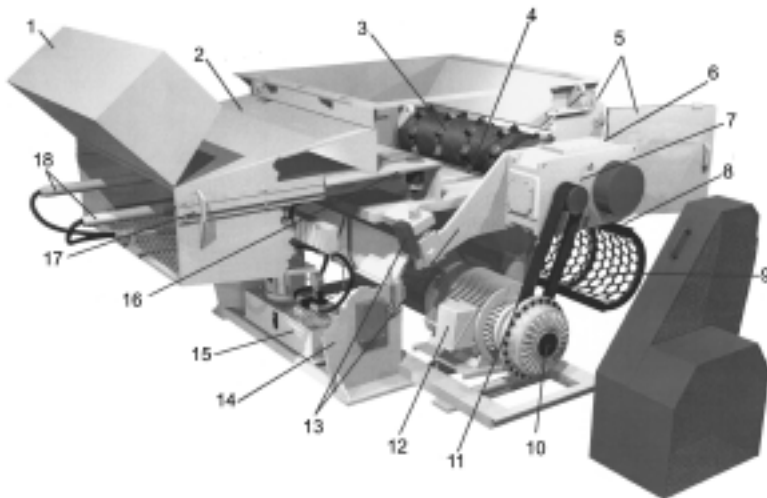

- 1 Hinged cover provides protection to ram drive cylinders and allows easy access for cleaning.
- 2 Heavy shelf over ram cavity to protect against impact with heavy parts.
- 3 Cutting rotor is engineered for durability and carries a Limited Lifetime Warranty. Cutting inserts are precision fit for easy maintenance.
- 4 Anvil has a replaceable counterknife plate with close tolerance profile.
- 5 Hinged clean-out access doors with safety switches to access screen and cutting rotor for maintenance.
- 6 High quality, double row, self-aligning spherical outboard mounted roller bearings to prevent contamination.
- 7 Oversized reduction gearbox rated to crush rock.
- 8 Flanged discharge to accommodate assortment of pneumatic and mechanical conveyance systems.
- 9 Sizing screens from 3/8 to 3" add economical production of consistent particles in one pass.
- 10 Fluid coupling absorbs micro vibrations and converts torque under load.
- 11 Banded belt drive provides positive transmission and protection of drive train.
- 12 High quality, energy efficient drive motors with thermocouple interlocks.
- 13 Torque arm with disc springs to shock absorb gearbox. Equipped with shut down switch to limit damage from tramp metal.
- 14 Heavy side walls, braces and reinforcements.
- 15 Heavy duty hydraulic pump package reacts quickly to high shock loads. Hydraulic system includes a 2-stage pump, oversized cooling capacity and large reservoir.
- 16 Process ram provides precision feed of material to cutting rotor. Ram quickly adjusts to different load variables to maximize processing efficiency.
- 17 Quick change oversized ram guide rails.
- 18 Heavy dual cushioned hydraulic cylinders to advance process ram. Cylinders are secured with reinforced, vibration dampening clamps.