

CENTRAL FILTER CHAMBERS FOR VACCUM PUMP PROTECTION

The filter system is used as a central dust and fine collection receiver to protect the vacuum pump from damage. It operates as part of a central conveying system and is controlled by the central conveying control panel.

Sterling central filters are designed to protect the central vacuum pump and to run for continuous, 24 hour operation. The central filter is made out of corrosion and abrasion resistant stainless steel and cast aluminum.

The cleaning of the integrated filter is accomplished automatically with either implosion or compressed air blowback. The see-through collection chamber is easily removed by quick disconnects. The unit is easy to operate, access, and maintain.



Features

- Filter surface area of 50 sq. ft. (4.64 m²), rated for systems up to 360 cfm.
- 24 V DC control voltage
- Operates at 60-80 PSI (4.1-5.5 bar)
- Wall-mount
- See-through plexiglass collection chamber with quick disconnects
- Line sizes available: 1.5 (40 mm), 2 (50 mm), 2.5 (65 mm), 3 (76 mm), 3.5 (88 mm), or 4 (110 mm)
- Local I/O control
- Designed for central conveying applications
- Shipping weight: 85 lbs.

Options

- Leg kit for floor mounting
- Mounting bracket for SPC pump mounting
- Compressed air blowback with or without integrated controller (110 V AC or 24 V DC)
- 110 V AC control voltage
- Distributed I/O control
- Cyclone pre-filter for high dust applications
- SFC-SC filter

SFC-S SERIES

Central Vacuum Safety Filter

SPECIFICATIONS

Wall Mount

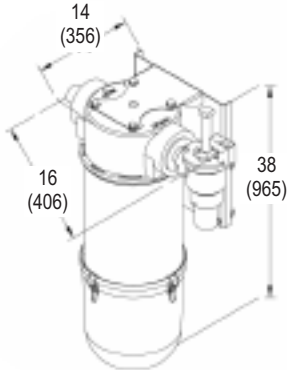

Floor Mount

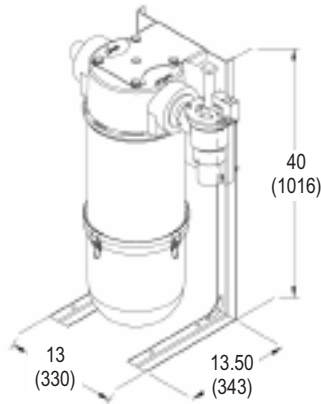

SPC Pump Mount

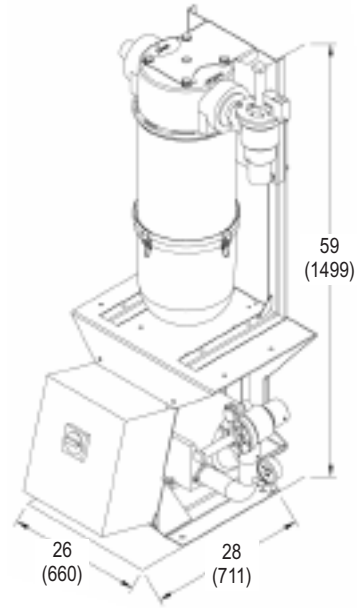

All dimensions are in inches and (mm) unless specified otherwise.

FILTER CLEANING OPTIONS

Implosion
Blowback

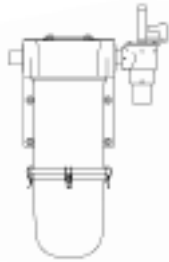

Compressed Air
Blowback

