

2010, 2012 ROYAL SERIES



Water Temperature Control System

RUGGED, RELIABLE, ADVANCED: FOR SUPERIOR TEMPERATURE CONTROL

Only the leader in temperature control could bring you a temperature control unit as rugged, reliable, and advanced as the Sterling Royal™ Series. Its new state-of-the-art design features simplified internal cast or non-ferrous fluid circuit with 40% fewer connections and 80% fewer mechanical parts. It also features a new higher-efficiency pump for higher flow rates at lower pressure. The result is dramatically enhanced water flow for superior temperature control.



Features

- Compact, rugged cabinet with easy access side panels
- Cast-and-flange design to reduce connection points
- Non-fused lockable rotary disconnect
- Independent high temperature safety thermostat
- Half- and full-heat capability
- Dual stage Incoloy™ immersion heater with IEC contactors
- NEMA 12 electrical enclosure
- 1/4" cooling solenoid valve on 3/4 to 3 hp (0.56 to 2.24 kW) models; 1/2" slow-close cooling solenoid valve on 5, 7.5, & 10 hp (3.73, 5.60, & 7.46 kW) models
- Forward-facing liquid-filled To and From Process pressure gauges
- Independent high temperature safety thermostat
- Non-fused lockable rotary disconnect
- M2B+ microprocessor controller includes diagnostics features with 2 line x 20 character LCD display
- 3/4" water supply connection, 1.5" process connections; valve size matches drain size
- Motor circuit protection
- Automatic vent sequence
- 150 psig (1,034 kPa/10.3 bars) pressure relief valve
- 3-year parts and labor warranty at the factory
- 5-year controller warranty
- Lifetime warranty on wetted cast components
- Lifetime pump seal (subject to factory review)
- Adjustable low supply water pressure switch; factory-set at 16 psig (110 kPa/1.1 bars)

Options

- Remote Control Enclosure with 20 ft. cable (additional cable available/ft.)
- 12, 18, 24, 36, 48 kW heater sizes available
- Maintained START switch (push to stop, twist to start)
- Manual bypass
- Closed loop heat exchanger, with 1/2" solenoid
- Quick cool switch
- Pressure regulator/relief valve; for water supply, shipped loose
- Auto system water purge; shipped loose
- Y-strainer; shipped loose
- Hammer arrestor
- Ten-foot power cord; no plug, shipped loose
- Rubber feet; in lieu of casters
- 3/4", 1", 1-1/4" cooling solenoid slow-close valve
- Modulating valve, body size; specify Cv valve when ordering
- 300°F operations; includes silicon carbide/silicon carbide seal (requires 55 psig water supply pressure minimum)
- General fault alarm; audible & visual
- Brass construction
- TEFC motor
- M2B+ options include: 4 to 20 mA remote setpoint and retransmission of process variable, setpoint, or flow rate; 232 Modbus, RS-485 Modbus, or RS-485 SPI communications; Remote probe; digital flow meter
- Common wiring and piping for two zone
- 208/3/60 VAC; 200-400/3/50 VAC; 575/3/60 VAC
- UL-, cUL-listed subpanel
- CE certification

2010, 2012 ROYAL SERIES

Water Temperature Control System

SPECIFICATIONS

Model Number 460 230	Pump, hp (kW)	Flow, gpm (lpm)	Pressure, psig (kPa)	Height, in. (cm)	Width, in. (cm)	Depth, in. (cm)	Ship. weight, lbs. (kg)
2010, 9 kW heater	0.75 (0.56)	30 (113.6)	25 (172.4)	28.75 (73)	13 (33)	28 (71.1)	210 (96)
	1 (0.75)	35 (132.5)	30 (206.9)	28.75 (73)	13 (33)	28 (71.1)	210 (96)
	2 (1.5)	50 (189.3)	30 (206.9)	28.75 (73)	13 (33)	28 (71.1)	210 (96)
	3 (2.24)	60 (227.1)	35 (241.3)	28.75 (73)	13 (33)	28 (71.1)	210 (96)
	5 (3.73)	90 (340.7)	50 (344.8)	28.75 (73)	13 (33)	28 (71.1)	240 (109)
	7.5 (5.6)	120 (454.2)	50 (344.8)	28.75 (73)	13 (33)	28 (71.1)	240 (109)
2012, 9 kW heater	0.75 (0.56)	30 (113.6)	25 (172.4)	48 (122)	13 (33)	28 (71.1)	210 (96)
	1 (0.75)	35 (132.5)	30 (206.9)	48 (122)	13 (33)	28 (71.1)	210 (96)
	2 (1.5)	50 (189.3)	30 (206.9)	48 (122)	13 (33)	28 (71.1)	210 (96)
	3 (2.24)	60 (227.1)	35 (241.3)	48 (122)	13 (33)	28 (71.1)	210 (96)
	5 (3.73)	75 (283.9)	50 (344.8)	48 (122)	13 (33)	28 (71.1)	240 (109)
	7.5 (5.6)	90 (340.7)	50 (344.8)	48 (122)	13 (33)	28 (71.1)	240 (109)
	10 (7.46)	125 (473.1)	55 (379.2)	48 (122)	13 (33)	28 (71.1)	270 (123)

Note: Contact factory for additional lead time on 7.5 hp pumps.

FULL LOAD AMPS @ 460VAC/3/60

Pump, hp	9 kW htr	12 kW htr	18 kW htr	24 kW htr	36 kW htr	48 kW htr
0.75	12.7	16.5	24.0	31.6	47.4	62.4
1.00	13.1	16.9	24.4	32.0	47.8	62.8
2.00	14.7	18.5	26.0	33.6	49.4	64.4
3.00	16.1	19.9	27.4	35.0	50.8	65.8
5.00	18.9	22.7	30.2	37.8	56.6	71.6
7.50	22.3	26.1	33.6	41.2	57.0	72.0
10.00	26.0	30.0	37.0	45.0	60.0	75.0

PRESSURE DROP FLOW AND LOSS

Pump, hp	flow, gpm (lpm)	loss, psi (kPa)	Recommended NPT pipe size for flow rate
0.75	30 (113.6)	0.0 (0.0)	1-1/4"
1.00	35 (132.5)	1.0 (6.9)	1-1/4"
2.00	50 (189.3)	1.5 (10.3)	1-1/2"
3.00	60 (227.1)	2.0 (13.8)	1-1/2"
5.00	75 (283.9)	2.5 (17.2)	2"
7.50	90 (340.7)	3.0 (34.4)	2"
10.00	120 (454.2)	5.0 (34.4)	2-1/2"

Note: Recommended pipe size based on flow rate producing less than 10 ft/sec. velocity through pipe diameter.

2010, 2012 ROYAL SERIES



Water Temperature Control System

ROYAL SERIES COMPACT - DIRECT INJECTION

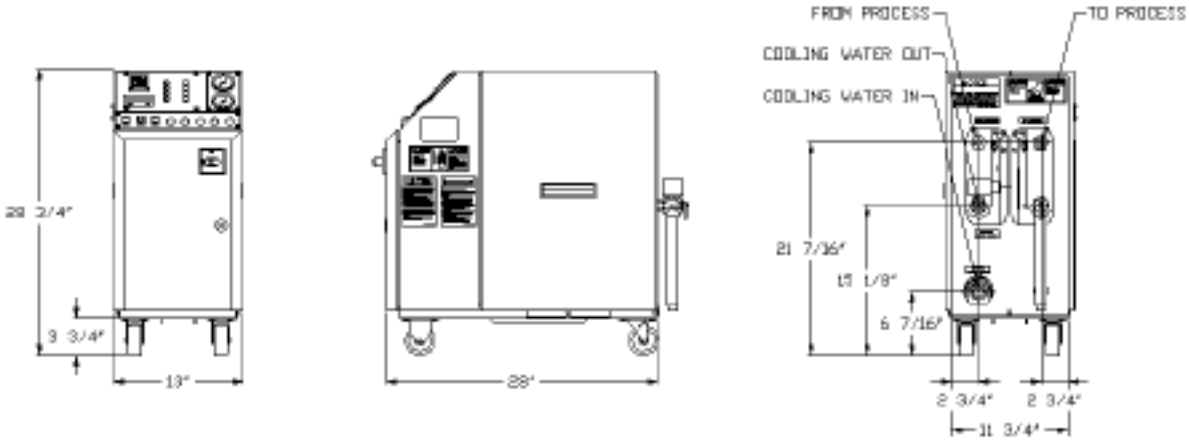

CLOSED CIRCUIT

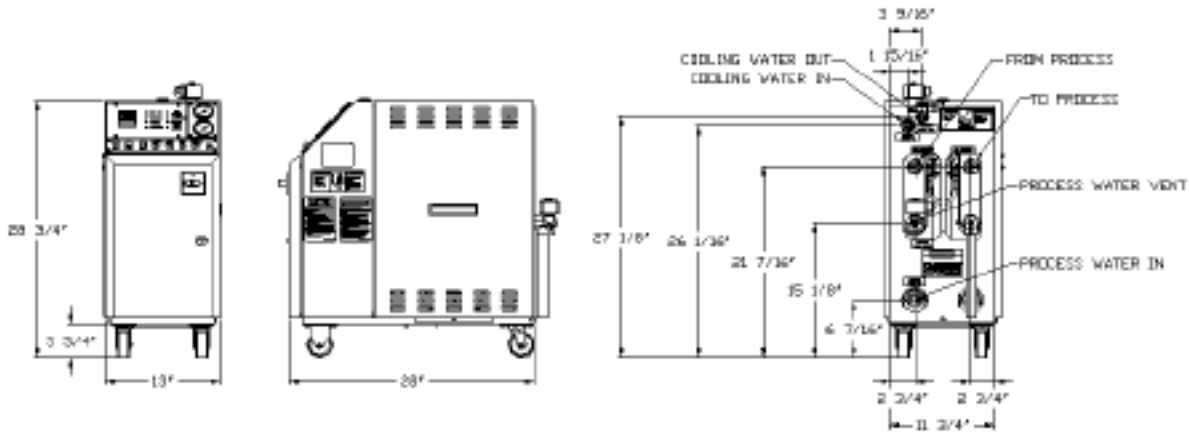

2010, 2012 ROYAL SERIES

Water Temperature Control System

ROYAL SERIES UPRIGHT - DIRECT INJECTION

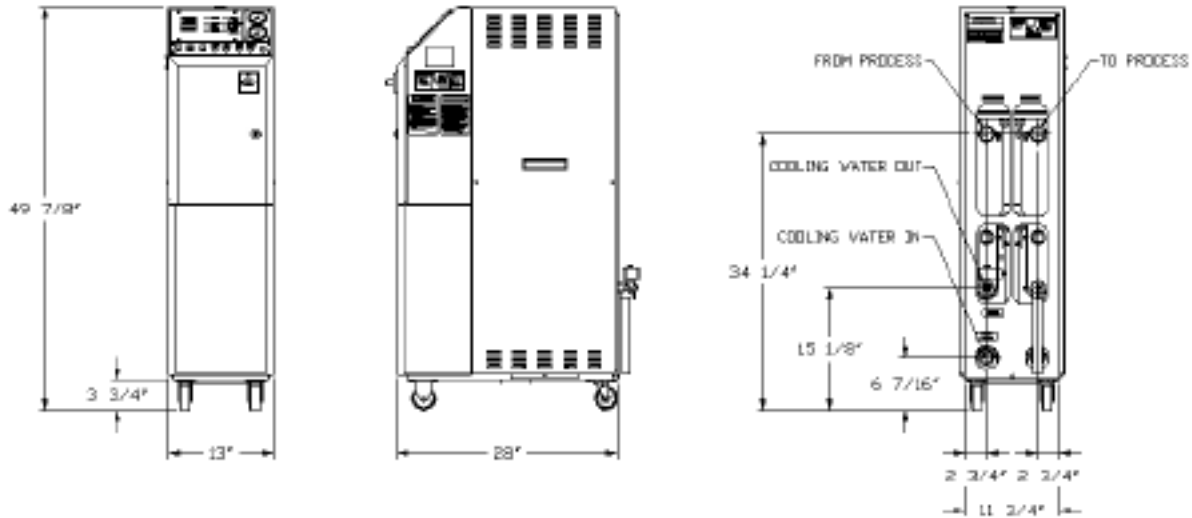

CLOSED CIRCUIT

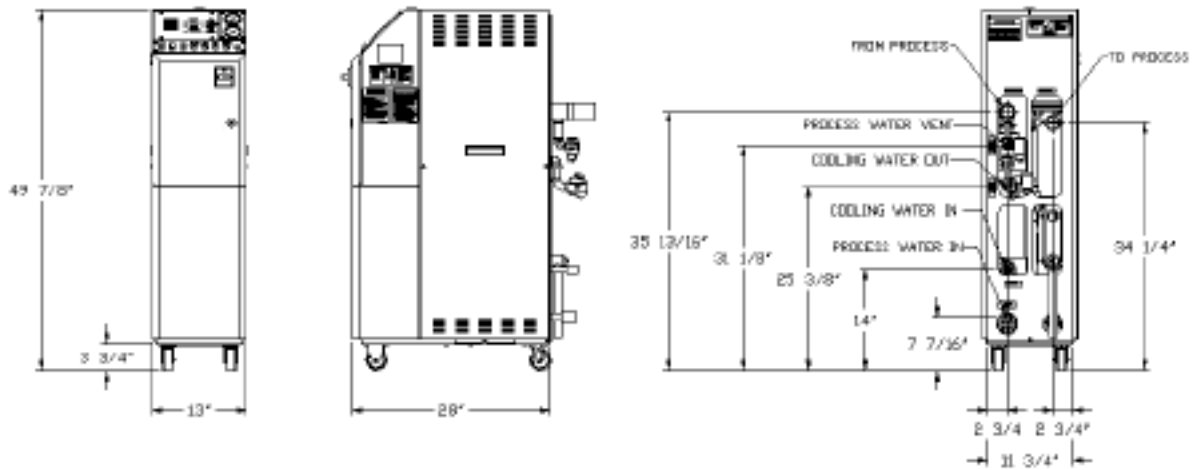

Note: Pictures on this page depict unit with 24, 36, or 48 kW heater options. For piping dimension for a unit with less than 24 kW, please refer to the compact unit.

2010, 2012 ROYAL SERIES



Water Temperature Control System

PUMP CURVES: 60 HZ

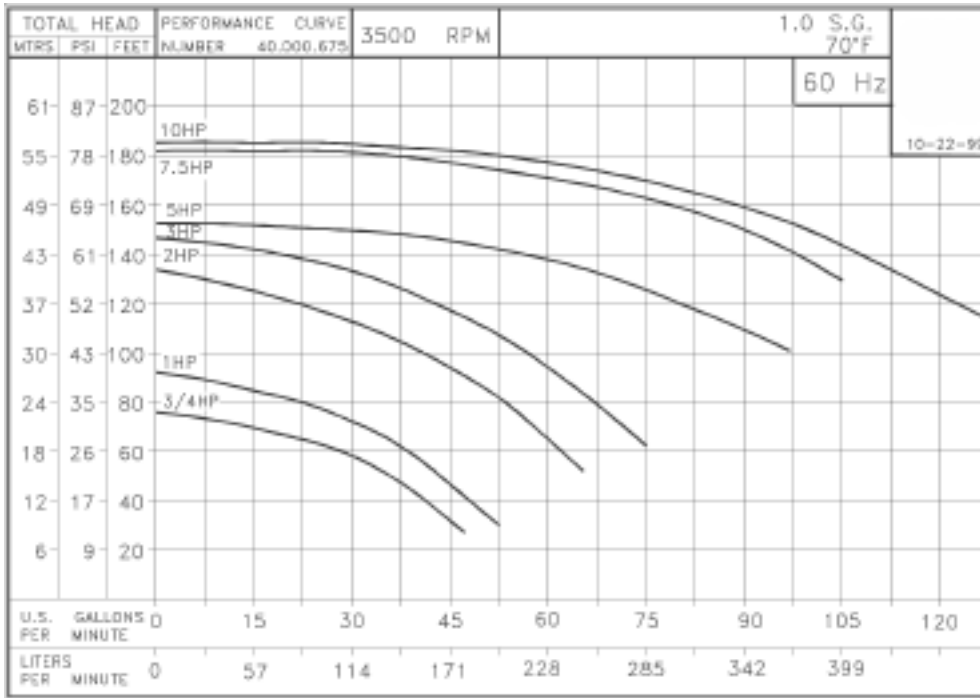

PUMP CURVES: 50 HZ

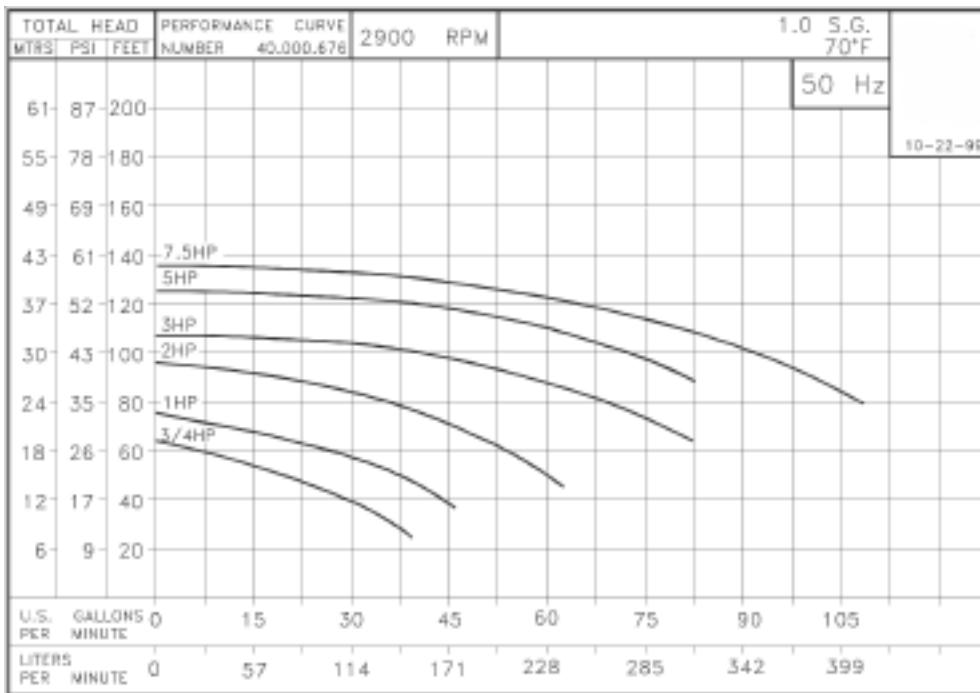

Note: Consult factory for 10 HP pump curves.

2010, 2012 ROYAL SERIES

Water Temperature
Control System

NOTES:

