

9012 SERIES



Positive/Negative Pressure
Temperature System



STAY IN PRODUCTION WHILE YOU WAIT TO FIX THAT LEAKING MOLD

Troublesome cooling circuit leaks in processes can result in serious production losses. The leaks may be due to small stress cracks, which leak when under pressure.

Sterling's solution? Our temperature controllers use a liquid Venturi to draw water through the mold. Precise temperature control is provided by the operation of a microprocessor controller which activates a heater or cooling water solenoid as required.

Options

- Pressure gauge
- Power cord for ease of installation
- 3 hp pump is available
- 12 kW, 18 kW, or 24 kW are available

Features

- Unit operates in either a positive or negative mode. Adjusts easily via the operation of an external hand-operated valve handle
- Three phase 9 kW electric immersion heaters are suspended vertically for long heater life
- Designed for easy substitution for any standard water temperature controller. It uses the same hose and piping connections and does not require external air source
- An integral air separator automatically vents air from the system. Eliminates manual requirement for the operator
- Reduces production losses by enabling you to postpone repairs until the end of a production run
- Under negative pressure operation, water cannot leak out as in a conventional pressure system
- Quick interchangeability reduces downtime by getting you back into production fast

9012 SERIES

Positive/Negative Pressure
Temperature System



Specifications - Model 9012

Temperature Range	Up to 180°F
Flow Through Process	Up to 24 gpm (negative mode) Up to 35 gpm (positive mode)
Pump	2 HP Standard
Pipe Connections	Process 1 1/4" Cooling Water 3/4"
Heater	9 KW
Total Running Amps	14.5 Amps (460/3/60)
Shipping Weight	220 lbs.

One year parts warranty

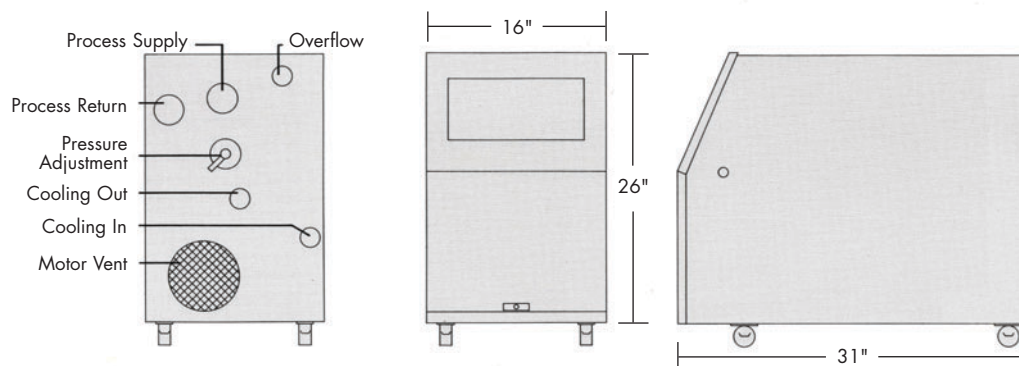

PRODUCT. PERFORMANCE. EXCELLENCE.

2900 S 160th Street
New Berlin, Wisconsin 53151 USA
Ph: 262.641.8610 Fax: 262.641.8653



Granulate



Regulate



Automate



Integrate