

VERSITILITY AND DURABLE CONSTRUCTION FOR A WIDE RANGE OF APPLICATIONS

Modular takeoff boxes from Sterling are designed for free-flowing materials and provide durable construction in a simple, modular design. The MTO Series takeoff boxes feature stainless steel construction with lightweight aluminum tube assemblies. The versatile modular design is compatible with a wide range of applications and allows for easy assembly and cleanout.

MTO takeoff boxes are available in single or multiple lines with styles including complete clean-out type with tapered bottom, or box type, which provides various material line takeoff configurations. All compartments have adjustable tubes or air/material balancing and a filter for air inlets. Check the available clearance below flange, and make sure to pick the correct box type.



Features

- Stainless steel box
- Aluminum tubes
- Material viewport on body styles A, B, and C
- Available sizes: 16 (406 mm), 10 (254 mm), and 7 (178 mm) square flanges.

Options

- Material clean-out gate
- Blank plate
- Adapter plate to mate to 7 x 7 or 9 x 9 square flange drying hoppers
- Take-off tubes: 1.5 , 2 , 2.5 , 3 , 3.5 , 4
- Dual tube models for regrind and non-freeflowing materials
- Consult factory for dry-air conveying applications or powder conveying applications

MTO SERIES

Modular Take-Off Compartments

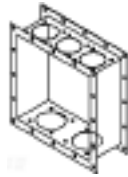

Style A



Style B



Style C



Style D



Style E

SPECIFICATIONS

Style	Square Flange Size in. (mm)	Height, in. (mm)	Bolt pattern		Number of tubes per MTO box					
			Top	Bottom	1.5"	2.0"	2.5"	3.0"	3.5"	4.0"
A	16 (406)	6 (152)	16 holes	16 holes	3	3	3	3	3	2
B	16, 10 (406, 254)	8 (203)	16 holes	12 holes	3	3	3	1	1	1
C	10 (254)	6 (152)	12 holes	12 holes	2	2	2	1	1	n/a
D	10, 7 (254, 178)	5.5 (140)	12 holes	8 holes	2	2	2	n/a	n/a	n/a
E	7, 4.5 (178, 114)	4.5 (114)	8 holes	5 holes	1	1	1	n/a	n/a	n/a

BOLT PATTERNS

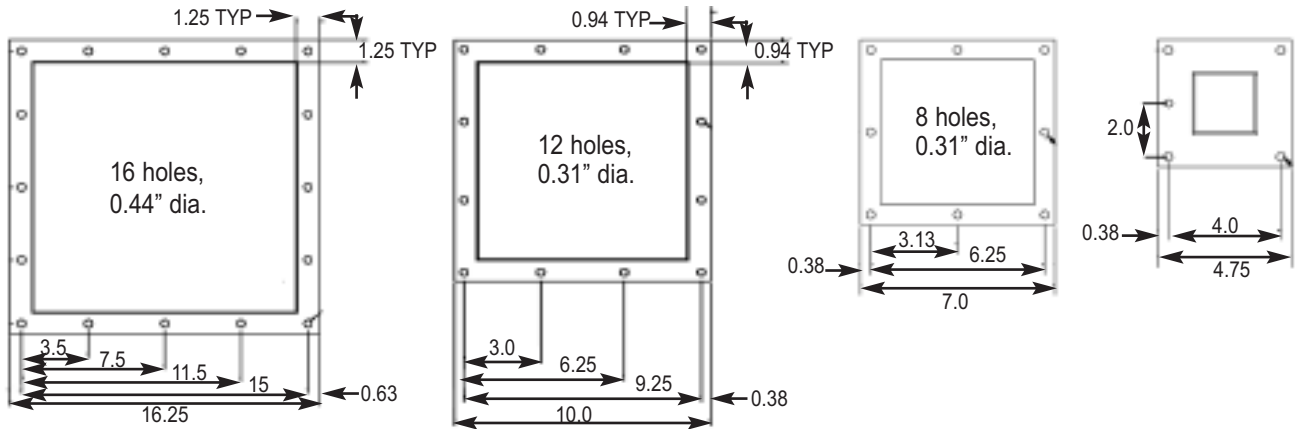

CLEAN-OUT GATES

Style	H, in. (cm)	W, in. (cm)	D, in. (cm)	A, in. (cm)	B, in. (cm)
A	6.94 (17.6)	16.25 (41.3)	16.25 (41.3)	3.14 (7.9)	6.38 (16.2)
B, C	4.31 (10.9)	10 (25.4)	10 (25.4)	3.06 (7.8)	6.38 (16.2)
D*	5.19 (13.2)	7 (17.8)	7 (17.8)	2.38 (6.1)	4.75 (12.1)

* Style D MTO take-off boxes use a Style E take-off box with a bottom-mounted Style E cleanout assembly

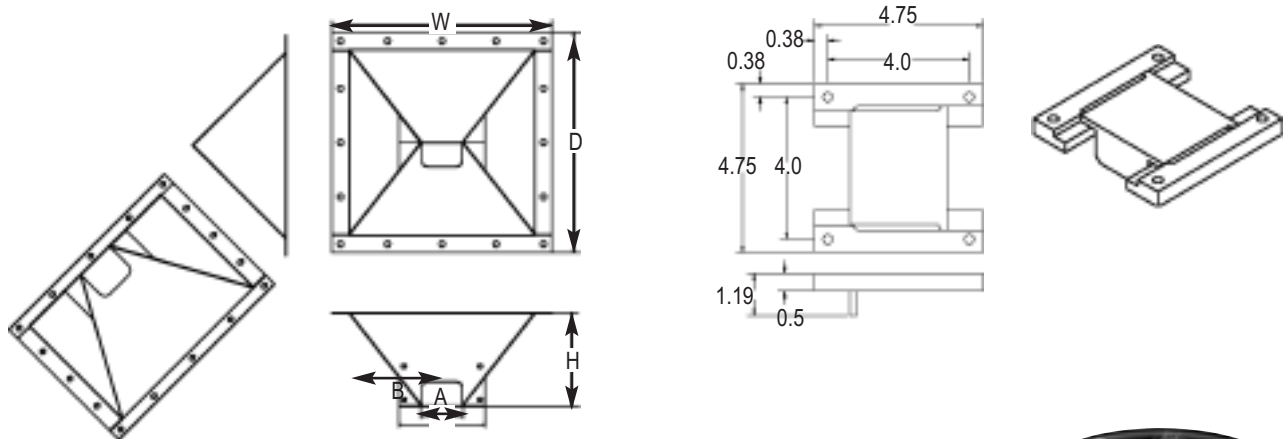

Specifications, appearances and dimensions are subject to change without notice.

