



HARMO HRXi SERIES

HRX-80SWi and HRX-80GWi

SUPERIOR PERFORMANCE AND SMART PROGRAMMING

Superior performance, powered by the industry's most complete fully end-user programmable controls package, the HRXi Series from Harmo brings every molder the tools necessary to deliver value to every job—large or small. Smart programming, fully editable screens and limitless I/O capacity are just a few of the hallmarks that make this the robot of choice for those serious about automating molding machines to the greatest extent possible.



Features

- All axis AC digital servo actuation (absolute encoder)
- Three-dimensional axis movement
- Thick-walled aluminum extrusion traverse beam with steel sub-weldment
- C-Axis 90° wrist flip unit
- One (1) part vacuum circuit with detection
- One (1) mechanical circuit with detection
- One (1) sprue grip circuit with detection
- SPI ready with 32 Pin DIN plug
- Air requirement is: 80 PSI
- Power requirements: AC 200 ± 20% (50/60 Hz) - Three Phase
- Operator or non-operator side unload
- Two (2) year parts warranty
- One (1) year on-site labor (excluding travel expenses)

Options

- Two-stage telescopic vertical arm construction for low overhead environment (all HRX-300 and larger robots are two-stage telescopic standard)
- A-Axis pneumatic two-position 0-90 or 0-180 degree wrist rotation
- Additional pressure and/or vacuum circuit(s)
- Machine platen spacer with custom mounting bolt hole pattern
- EOAT quick-change system (robot and EOAT side)
- Extended stroke lengths (varies by model)
- End of beam support
- EuroMap 12 or 67 IMM interface (SPI interface/plug is standard)
- SPI interface plug kit (10 amp/32 pin) for molding machine side
- Transformer for voltages other than 200-220 VAC/three phase

HARMO HRXi SERIES

HRX-80SWi and HRX-80GWi

SPECIFICATIONS

Model	Vertical Stroke (mm)		Strip stroke (mm)		Traverse stroke (mm)	Max. payload (kg)	Machine Weight (kg)
	Main	Sub	Main	Sub			
HRX-80SWi	650 (750)	—	425	—	1200 (1600)	3 (including EOAT)	210
HRX-80GWi		700 (800)	265	265			225

Model	Working air pressure (Mpa)	Air consumption (N _l /cyc) *1	Drive system	Control method	Power supply (V)	Power consumption (W)
HRX-80SWi	0.6	0.7	Digital AC servo motor (3/5 axes)	PTP•CP	3P 200ACV+10%/-15% (50Hz/60Hz)	1350
HRX-80GWi		0.8				1950

*1 Additional 63N_l/min is consumed for each vacuum ejector

DIMENSIONS (MM)

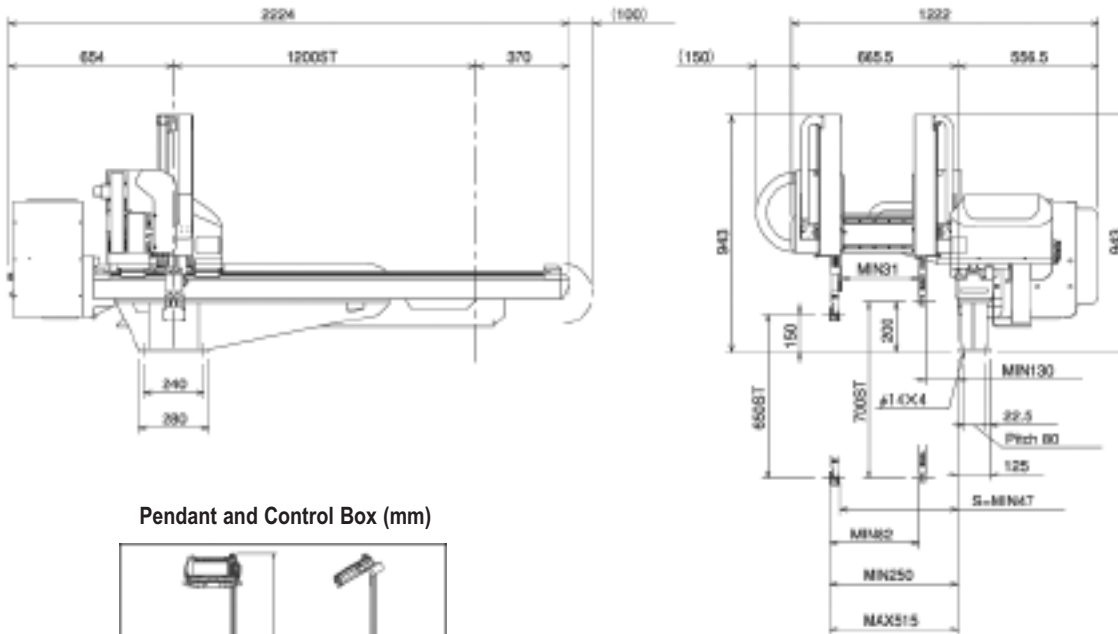

Pendant and Control Box (mm)

