

HRXf SERIES



Three and Five Axis
Full Servo Robots



HRXf SERIES

With pinpoint accuracy and repeatability, rugged durability, and high speed performance, the HRXf Series Full Servo Extraction Robots are redefining the automation industry. These powerful yet very cost effective robots are perfect for automating horizontal molding machines from 40–1,000 tons in both three and five axis configurations.

The HRXf Series features the highest quality linear guides on all axes, employing THK rail and bearing systems. The redesigned kick frame provides more rigidity for enhanced support and repeatability. The thick-walled aluminum extrusion traverse beam with ridged steel sub-weldment suppresses vibration and maximizes resistance to deflection during critical operations. Smaller units are available with single or two-stage telescopic vertical arms. The two-stage telescopic configuration is standard on HRX-300 and larger models allowing for easy placement in low ceiling environments. This configuration also offers faster take-out times due to the compound arm construction method.

HRXf Series robots are backed by the industry's largest customer service support group and a full compliment of factory trained automation technicians.

Features

- 26 spare outputs / 20 spare inputs
- Absolute encoder digital AC servo motor all-axis actuation
- Traverse beam-end mounted control cabinet (floor-based cabinet available upon request)
- Fully compliant SPI ready interface (32 pin/ 10 amp) - also available in Euromap 12 or 67
- Robot "Not-in-Use" function - allows independent IMM operation
- One (1) vacuum circuit
- Two (2) pressure circuits
- A or B side pick (no mechanical modifications necessary)
- Ultra thin C-Axis wrist flip

Options

- Additional vacuum circuit(s)
- Additional pressure circuit(s)
- A-Axis pneumatic wrist rotate - 0-180°
- Pressure monitor—alarm on at lower pressures
- EOAT gate cut circuit—gate cut circuit in EOAT
- Traverse end gate cut—gate cut(s) at the end of traverse frame
- Signal tower—red, yellow, and green
- End of arm tooling quick change system
- Extended stroke lengths (varies by model)

HRXf SERIES

Three and Five Axis Full Servo Robots



RCA2600 Series Controller

HRXf Series robots are equipped with a highly efficient and easy-to-use RCA-2600 Next Generation Controller. This uniquely intelligent controller stores as many as 100 mold setups and confirms up to 28 robot motions at actual speed before automatic operation. Additional mold setups can be stored using the standard USB port or the optional disk drive. Sequences are easily programmed via an easy-to-see 6.5" color LCD touch panel interface. Manual operation keys are grouped separately for direct access to frequently used functions, making operations quick and easy.

Features

- All axis 3D "Fast Path Motion"
- Multiple home positions - rack mold ready
- Lightweight – compact – ergonomic hand-held, color graphic user interface (GUI)
- LED mode indicators
- JOG dial for easy position teaching
- Soft-touch keys for manual operation
- Multi level password protection
- Screen saver mode
- Three-position safety switch
- 100 mold memory – on board
- USB port for unlimited off-line file storage
- Global device net capable for increased I/O
- Teach speeds/timers/positions on-the-fly
- 99 position all-axis palletizing
- Wrist flip on-the-fly
- Reject counter / sampling mode

HRXf Series Specifications

Model Number / Description		Main Arm Vertical Stroke mm (in.)	Main Arm Kick Stroke mm (in.)	Traverse Stroke mm (in.)	Sub Arm Vertical Stroke mm (in.)	Sub Arm Kick Stroke mm (in.)	Max. Payload
HRXf80S	Single stage, single arm	650 (25.6)	425 (16.7)	1200 (47.2)	N/A	N/A	6.6 lbs.
HRXf80SW	Telescopic, single arm		300 (11.8)				
HRXf80G	Single stage, sub arm		265 (10.4)				
HRXf80GW	Telescopic, sub arm		705 (27.8)	1400 (55.1)	N/A	N/A	11 lbs.
HRXf150S	Single stage, single arm	800 (31.5)	584 (23.0)				
HRXf150SW	Telescopic, single arm		552 (21.7)				
HRXf150G	Single stage, sub arm		850 (33.5)	584 (23.0)			
HRXf150GW	Telescopic, sub arm		552 (21.7)	1600 (63.0)	N/A	N/A	11 lbs.
HRXf200S	Single stage, single arm	900 (35.4)	584 (23.0)				
HRXf200SW	Telescopic, single arm		552 (21.7)				
HRXf200G	Single stage, sub arm		950 (37.4)	584 (23.0)			
HRXf200GW	Telescopic, sub arm		552 (21.7)	1800 (70.9)	N/A	N/A	22 lbs.
HRXf300SW	Telescopic, single arm	1100 (43.3)	1015 (40.0)				
HRXf300G	Single stage, sub arm		861 (33.9)				
HRXf300GW	Telescopic, sub arm		1150 (45.3)	861 (33.9)			
HRXf500SW	Telescopic, single arm	1300 (51.2)	1100 (43.3)	2000 (78.7)	N/A	N/A	33 lbs.
HRXf500S	Single stage, single arm		1300 (51.2)				
HRXf500GW	Telescopic, sub arm		1045 (41.1)				

Power Source: AC200V - Three Phase ±10% - 50/60 Hz
Air Consumption: 80 PSI

HRXf SERIES

Three and Five Axis
Full Servo Robots

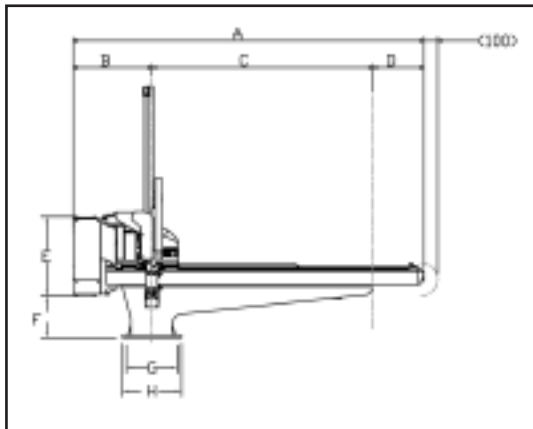

SINGLE STAGE VERTICAL ARM (MM)

Model Number	A	B	C	D	E	F	G	H
HRXf80S/G	2130	560	1200	370	580	127	240	280
HRXf150S/G	2300	570	1400	330	580	202	240	280
HRXf200S/G	2540	570	1600	370	580	302	370	430

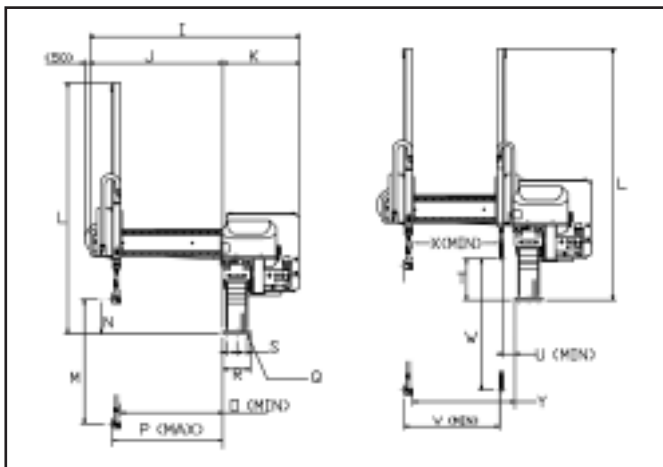

SUB ARM (MM)

Model Number	T	U	V	W	X	Y
HRXf80G	200	95	79	700	30	215
HRXf150G	200	100	93	850	30	231
HRXf200G	300	85	93	950	30	210

SINGLE STAGE VERTICAL ARM (MM)

Model Number	I	J	K	L	M	N	O*	P	Q	R	S
HRXf80S/G	1209	666	544	1354	650	150	47	515	14X4	125	40
HRXf150S/G	1519	978	541	1597	800	150	48	815	14X6	170	60
HRXf200S/G	1519	963	556	1817	900	250	33	800	18X6	200	75

* Dimension applies to S model only

HRXf SERIES

Three and Five Axis
Full Servo Robots

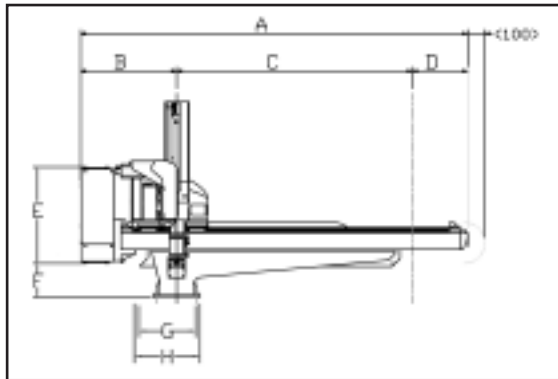

TWO-STAGE TELESCOPIC ARM (MM)

Model Number	A	B	C	D	E	F	G	H
HRXf80SW/GW	2130	560	1200	370	580	127	240	280
HRXf150SW/GW	2300	570	1400	330	580	202	240	280
HRXf200SW/GW	2540	570	1600	370	580	302	370	430
HRXf300SW/GW	2700	585	1800	315	611	375	470	530
HRXf500SW/GW	3047	630	2000	417	574	128	470	570

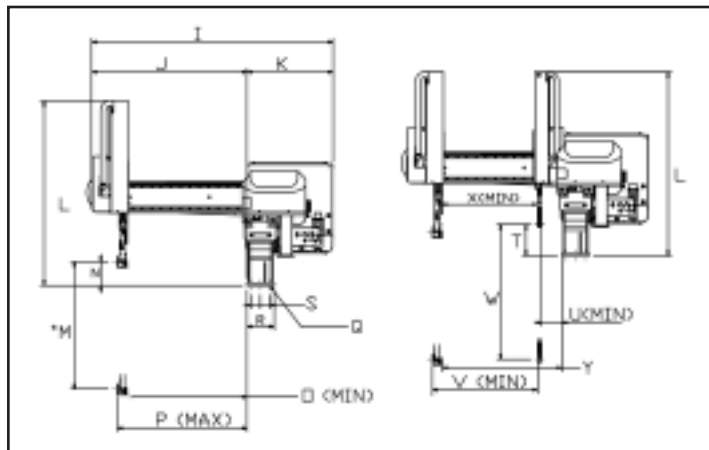

SUB ARM (MM)

Model Number	T	U	V	W	X	Y
HRXf80GW	200	130	82	700	31	250
HRXf150GW	200	130	97	850	35	263
HRXf200GW	300	115	97	950	35	248
HRXf300GW	350	115	88	1150	26	239
HRXf500GW	350	105	65	1300	N/A	250

TWO-STAGE TELESCOPIC ARM (MM)

Model Number	I	J	K	L	M	N	O*	P	Q	R	S
HRXf80SW/GW	1209	666	544	943	650	150	47	515	14X4	125	40
HRXf150SW/GW	1519	978	541	1160	800	150	48	815	14X6	170	60
HRXf200SW/GW	1519	963	556	1320	900	250	33	800	18X6	200	75
HRXf300SW/GW	1845	1288	556	1523	1100	300	33	1100	18X6	200	75
HRXf500SW/GW	2274	1696	578	1692	1300	300	170	1350	18X6	250	75

* Dimension applies to S model only

