

BP800 SERIES



Beside-the-Press Granulators

QUIET-RUNNING BESIDE-THE-PRESS FOR REGRIND

The BP800 Series granulators are designed for efficient beside-the-press regrind of reject components from injection molding, blow molding, and extrusion processes. Quiet-running and extremely versatile, they can be used with robot feed, conveyor feed or hand feed applications.

These sound-attenuating granulators are available in three models—BP810, 814, and 818. All provide excellent quality regrind with the added advantage of reduced maintenance costs.



Features

- Pivoting hopper, drop-down screen cradle and machined, bolted cutting chamber simplifies cleaning and maintenance
- Low profile, sound-attenuated infeed system for robot, hand or conveyor feed applications
- HCHC knives manufactured in-house utilizing Sterling's proprietary process for heat-treating ensure durability and long life

Options

- Motor: 7.5 to 10 HP (5.5 to 7.5 kW) TEFC motors
- Discharge: 1.25", 1.5", 2" or 2.5" vacuum take-off
- Knives: D2 components and wear-resistant package for abrasive applications
- Modular feed chutes

BP800 SERIES

Beside-the-Press Granulators

SPECIFICATIONS

Specifications			
Model	BP810	BP814	BP818
Cutting Circle	8.2" dia. (210mm)		
Avg Throughput (lbs/hr)	123	172	221
Cutting Chamber	8" x 10"	8" x 14"	8" x 18"
Rotor Knives	3-knife open-scooped with rotating end discs		
Discharge	Manual bin standard		
Motor	5HP (3.75 kW) TEFC standard		
Base	Full machine sound enclosure with casters		
Electrical Components	Start/stop button, with complete safety interlocks		
Controls	NEMA type 12		
Feed Height (manual chute)	47.5" (1206mm)		
Feed Height (front robot/conveyor chute)	59.1" (1502mm)		
Feed Height (rear robot/conveyor chute)	68.6" (1742mm)		
Overall Height (manual chute model)	59.4" (1507mm)		
Overall Length	45.0" (1144mm)		
Overall Width	30.3" (770mm)	34.3" (871mm)	38.3" (973mm)
Weight	1220 lbs	1400 lbs	1610 lbs

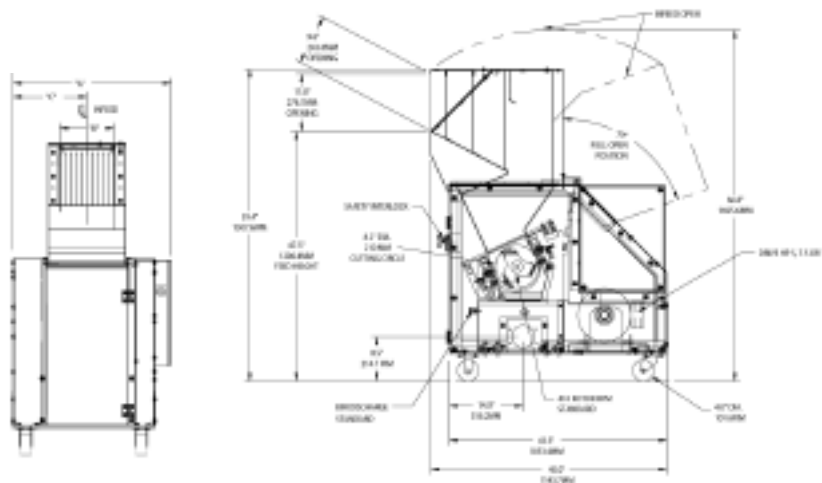
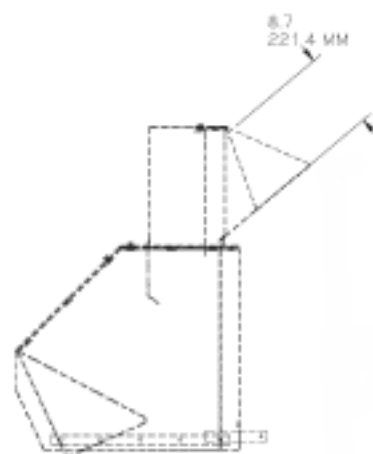
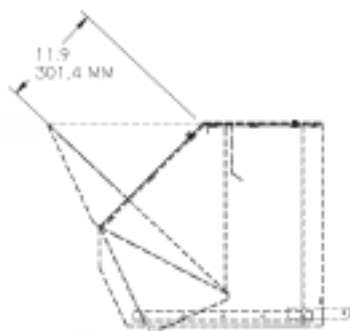

Dimensions				
Machine Model	A	B	C	D
BP810	30.3" (770mm)	10.2" (260mm)	14.3" (363mm)	16.5" (420mm)
BP814	34.3" (871mm)	14.2" (360mm)	16.3" (414mm)	20.5" (520mm)
BP818	38.3" (973mm)	18.2" (462mm)	18.3" (465mm)	24.5" (622mm)

Optional Feed Chute Drawings