



BESIDE-THE-PRESS GRANULATOR

BP800 SERIES BESIDE-THE-PRESS GRANULATORS

The BP800 Series granulators are designed for efficient beside-the-press regrind of reject components from injection molding, blow molding, and extrusion processes. Quiet-running and extremely versatile, they can be used with robot feed, conveyor feed or hand feed applications.

These sound-attenuating granulators are available in three models—BP810, 814, and 818. All provide excellent quality regrind with the added advantage of reduced maintenance costs.

Features

- Pivoting hopper, drop-down screen cradle and machined, bolted cutting chamber simplifies cleaning and maintenance
- Low profile, sound-attenuated infeed system for robot, hand or conveyor feed applications
- HCHC knives manufactured in-house utilizing Sterling's proprietary process for heat-treating ensure durability and long life

Options

- Motor: 7.5 to 10 HP (5.5 to 7.5 kW) TEFC motors
- Discharge: 1.25", 1.5", 2" or 2.5" vacuum take-off
- Knives: D2 components and wear-resistant package for abrasive applications
- Modular feed chutes



BP800 SERIES



Model	Cutting Circle	Throughput	Motor HP	Feed Height	Ship Weight
BP810	8.2" (210mm)	123 lbs/hr (58kg)	10 HP (7.5kW)	47.5" (1207mm)	1220 lbs (553kg)
BP814		172 lbs/hr (78 kg)			1400 lbs (635kg)
BP818		221 lbs/hr (100 kg)			1610 lbs (730kg)

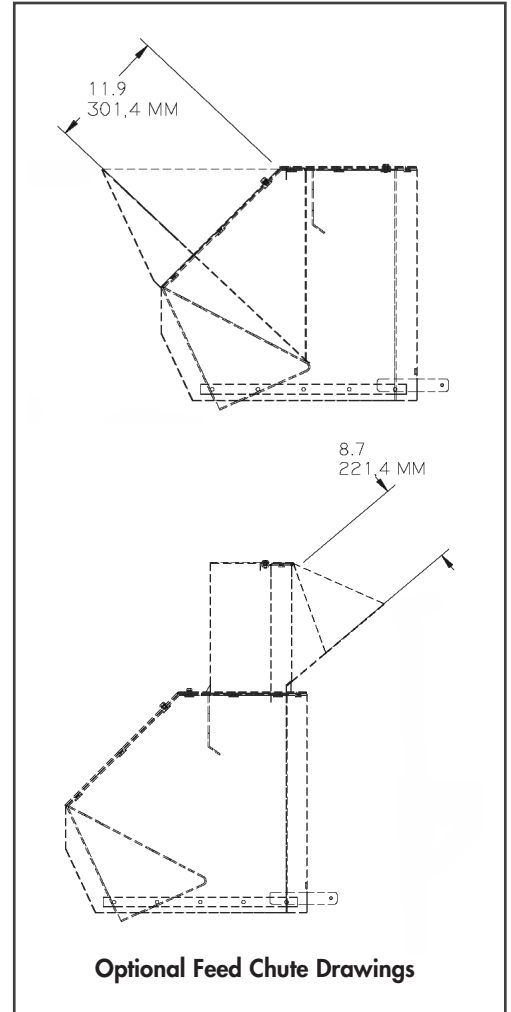
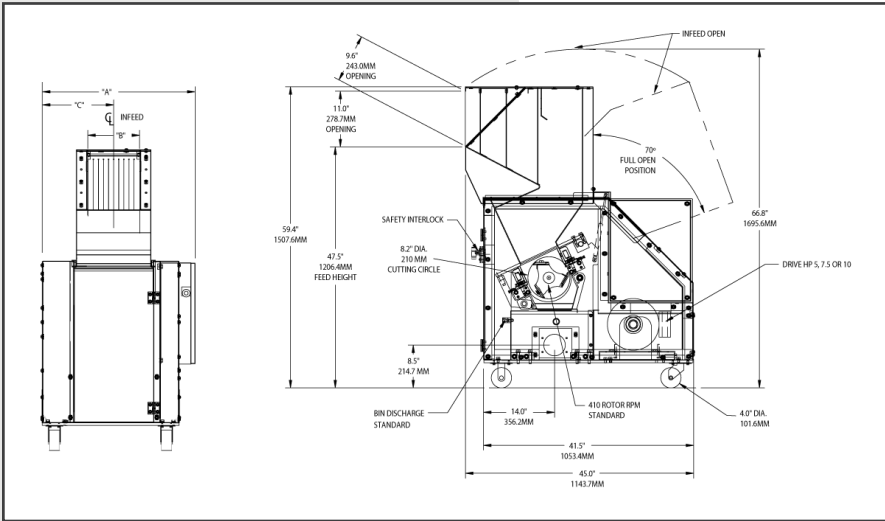

Sterling New Berlin
 2900 S 160th Street
 New Berlin, WI 53151 USA
 Tel: +1 262 641 8610
 Fax: +1 262 641 8653
www.sterlco.com

Sterling Schaumburg
 1100 E Woodfield Rd #550
 Schaumburg, IL 60173 USA
 Tel: +1 847 273 7700
 Fax: +1 847 273 7804

Sterling India
 Gat No. 191/1, Sandbhor Complex,
 Mhalunge, Chakan, Tal Khed,
 Dist. Pune 410501, India
 Tel: +91 21 35329112
 Fax: +91 20 40147576

Sterling Warsaw
 ul.Dziakowa 115
 02-234 Warszawa
 Tel: +48 22 390 9720
 Fax: +48 22 390 9724

Sterling Suzhou
 109 Xingpu Road SIP
 Suzhou, China 215126
 Tel: +86 512 8717 1919
 Fax: +86 512 8717 1916

