

**CENTRAL GRANULATOR****BP3263/3284 HD SERIES
CENTRAL GRANULATORS**

The BP3200 HD Series granulators have been designed with you, the processor in mind. They cover a wide range of applications including heavy extruder purgings, blow-molded flashings, thick sheet, pipe, large blow-molded parts (automotive, appliance, furniture, profiles), X-ray films, packaging films and large-capacity post-consumer products.

Ranging in horsepower from 200 HP to 400 HP, and with throughput capacities from 6,000 to 12,000 lbs./hr, Sterling's 3200 Series granulators offer heavy-duty design and high-capacity granulating for all your demanding applications. There is also an extensive range of features and options available in two model sizes: 32" x 63" and 32" x 84".

Features

- Hydraulic actuation system for hopper and cradle
- Slide-out pivoting discharge chute assembly
- Replaceable rotor-knife seats
- Bearings are close-fit, taper-mounted and adjustable
- Auto-Lube systems feeds a constant amount of lubricant for automated PM service

Options

- Wear-resistant package
- Simplified access for service and maintenance
- Clean-out is quick and easy, saving valuable time
- Reduces downtime and simplifies maintenance, saving you money
- Precise control for tight-tolerance applications, critical for high-capacity bulk film
- Programmable service cycle ensures proper lubrication of bearings—no worry
- Adjustable rotor knives with setting fixture



BP3200 SERIES



Selector Guide

Standard Features	Infeed	Cutting Chamber	Rotor			Base	Discharge	Motor		Drive Parts	Controls	Throughput* Lbs/Hr (Approx.)	Weight Lbs/Hr (Approx.)	Dimensions				
	Conveyor feed electro-hydraulic tilt	Split design, drop cradle, integral bearings, Chevron bed knives	3-knife open offset 36° C/C (Standard)	Staggered "HOG" (Optional)	Special Options	Low profile common plate	Airveyor L/R Side (12'/12'/14')	1200 RPM/TEFC (Standard)	Optional	Solid High-Inertia Flywheel/Sheave V-Belt Drive	NEMA Type 12 Safety Interlocks, Hydraulic Actuation	3/8" Screen 3-Knife Open Rotor		A	B	C	E	F
3			12-knife		Twin High Shear™ 5-Knife Open Hard-Faced Water-Cooled			200 HP				10,000	35,000	143-1/2	63-1/8	65-3/8	172-1/8	12
3284	Tray Feed Pipe Feed Sheet Feed	Raised Bed Knife Water-Cooled Wearplates	18-knife	30-knife		Std.	Front/Rear or Conveyor	250 HP	150-400 HP	Dual Flywheel	Motor	12,000	42,000	164-1/2	84-1/8	86-3/8	183-1/8	14

* Rates may vary with application and are based on 3/8" diameter screen



Twin heavy-duty hydraulic cylinders ensure smooth pivoting of the hopper and upper chamber.

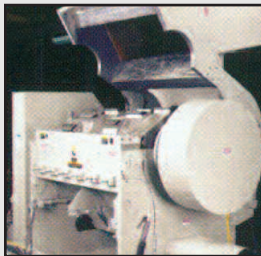

A hydraulic tilt mechanism for the infeed hopper provides complete access to the cutting chamber and rotor for simplified maintenance, saving time and money.

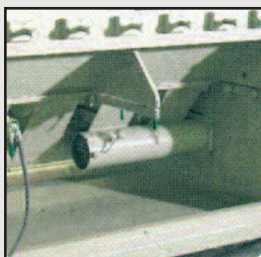

Discharge transition chutes roll out on tracks beneath the cradle for simplified access and cleaning. Twin-pipe discharge creates high-velocity material evacuation and efficient airflow, critical for high-capacity applications.

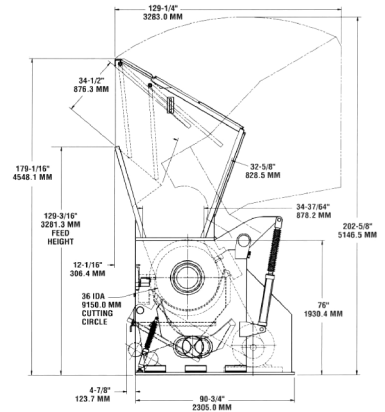
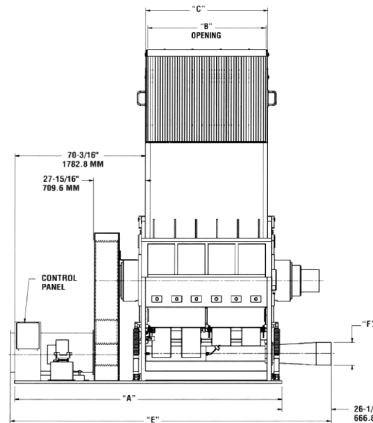

Sterling New Berlin
2900 S 160th Street
New Berlin, WI 53151 USA
Tel: +1 262 641 8610
Fax: +1 262 641 8653
www.sterlco.com

Sterling Schaumburg
1100 E Woodfield Rd #550
Schaumburg, IL 60173 USA
Tel: +1 847 273 7700
Fax: +1 847 273 7804

Sterling Warsaw
ul.Dziakowa 115
02-234 Warszawa
Tel: +48 22 390 9720
Fax: +48 22 390 9724

Sterling India
Gat No. 191/1, Sandbhor Complex,
Mhalunge, Chakan, Tal Khed,
Dist. Pune 410501, India
Tel: +91 21 35329112
Fax: +91 20 40147576

Sterling Suzhou
109 Xingpu Road SP
Suzhou, China 215126
Tel: +86 512 8717 1919
Fax: +86 512 8717 1916

