

# APEX SC-W SERIES



High Speed Servo Robot  
50-220 ton

## RIGID CONSTRUCTION FOR PRECISION POSITIONING AND STEADY MOVEMENT

The SC-W Series robot is for molding machines from 50-220 tons. It features 14 spare inputs and 14 spare outputs and PC based controls allow for greater flexibility during pre- and postmolding applications. The rigid steel traverse beam and sub-weldment provide for a near deflection-free travel.



### Features

- 3-axis AC brushless servo motors
- Full color 8.4" touch screen controls pendant
- C-90° pneumatic wrist rotate
- SPI interface, includes 32 pin 10-amp robot side connector
- Machine platen spacer with recommended mounting bolt hole pattern

### Specifications

- Spare I/O—Fourteen (14) inputs / Twelve (12) outputs
- SPI / Euromap 12 or 67 (see notes)
- Air requirement: 80 PSI clean dry air
- Electrical requirement: 220 VAC, Three phase, 60 Hertz
- Available in operator or non-operator side unload configurations
- One (1) year parts warranty (excluding on-site labor/travel expenses)
- Two (2) year warranty on the hand-held pendant

### Options

- Y-Axis Servo Wrist Pivot – Includes Pneumatic C-Axis 90° Wrist Flip
- A-axis pneumatic wrist rotation for part/runner orientation
- Additional pressure and / or vacuum circuit(s)
- Additional EOAT Quick-Change plates
- Non-SPI interface

### Mechanical Advantages Include:

- High precision linear guide systems—enhanced motion and repeatability
- All axis AC Servo motor drive for enhanced in-mold and secondary positioning
- One (1) vacuum-circuit and two (2) pressure circuits with verification
- End-of-arm-tooling “Quick-Change” system—Robot and EOAT side included
- Quick disconnects for electrical connections
- Telescoping vertical arm available for low overhead clearance; also provides enhanced speed

# APEX SC-W SERIES

High Speed Servo Robot  
50-220 ton

## SPECIFICATIONS

Model	Main Arm Vertical Stroke mm (in.)	Main Arm Kick Stroke mm (in.)	Traverse Stroke mm (in.)	Max. Payload
SC-750W	750 (29.5)	352 (13.9)	1020 (40.2)	6.6 lbs
SC-950W	950 (37.4)	472 (18.9)	1200 (47.2)	

## DIMENSIONS

Model Number	E, mm (in.)	H, mm (in.)	I, mm (in.)	K, mm (in.)	L, mm (in.)	N, mm (in.)
SC-750W	543 (21.4)	1121 (44.1)	1020 (40.2)	1814 (71.4)	1550 (61.0)	352 (13.9)
SC-950W	663 (26.1)	1241 (48.9)	1200 (47.2)	1994 (78.5)	1750 (68.9)	472 (18.6)

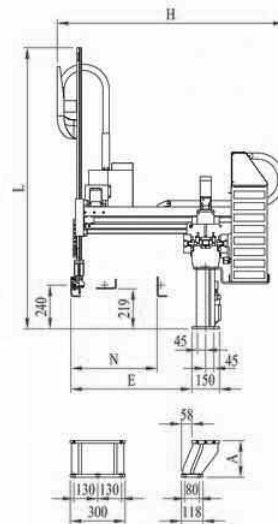
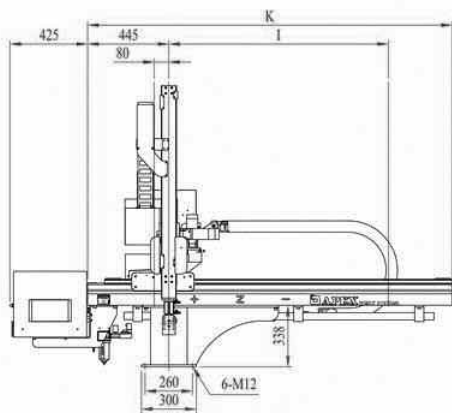

A, mm (in.)
100
150
200
250
300
350