

# APEX SC SERIES



3-Axis Servo Driven  
Traversing Robots

## RIGID CONSTRUCTION FOR PRECISION POSITIONING AND STEADY MOVEMENT

The SC Series robot is for molding machines from 80-4500 tons. The SC full AC servo robot will maximize molder productivity while minimizing capital expenditures. The PC based controls allow for greater flexibility during pre- and postmolding applications. The rigid steel traverse beam and sub-weldment provide for a near deflection-free travel.



### Features

- High-precision linear guide systems - enhanced motion and repeatability
- All-axis AC servo motor drive for enhanced in-mold and secondary positioning
- One (1) vacuum circuit and one (1) pressure circuits with verification
- End-of-arm tooling "quick-change" system - robot and EOAT side included
- Quick disconnects for electrical connections
- Telescoping vertical arm for low overhead clearance and enhanced speed
- Spare I/O - fourteen (14) inputs/fourteen (14) outputs
- SPI / Euromap 12
- Air requirement is: 80 PSI clean dry air
- Electrical requirement: 220 VAC, three phase, 60 hertz
- Available in operator or non-operator side unload configurations
- One (1) year parts warranty (excluding on-site labor / travel expenses)
- Two (2) year warranty on the hand-held pendant

### Options

- A-axis pneumatic wrist rotation for part/runner orientation
- Additional pressure and/or vacuum circuit(s)
- I/O expansion pack - up to 30 I/O
- Additional EOAT quick-change plates
- Euromap 67 interface
- Non-SPI interface

# APEX SC SERIES

3-Axis Servo Driven  
Traversing Robots

## SMALL BEAM (80-1000 TON) TRAVERSE ROBOTS

Model Number	Vertical Stroke, mm (in.)	Kick Stroke, mm (in.)	Traverse Stroke, mm (in.)	Payload, lbs.	
<b>Single stage vertical arm</b>					
SC-900-1710	864 (34)	360 (14.2)	1710 (67.3)	26.4	
SC-900-1950			1950 (76.8)		
SC-900-2130			2130 (83.9)		
SC-900-2600			2600 (102.4)		
SC-900-3000			3000 (118.1)		
SC-1100-1950	1064 (41.9)	480 (18.9)	1950 (76.8)		
SC-1100-2130			2130 (83.9)		
SC-1100-2600			2600 (102.4)		
SC-1100-3000			3000 (118.1)		
SC-1300-2130	1264 (49.8)	600 (23.6)	2130 (83.9)		
SC-1300-2600			2600 (102.4)		
SC-1300-3000			3000 (118.1)		
<b>Two stage telescopic vertical arm</b>					
SC-900T-1710	900 (35.4)	360 (14.2)	1710 (67.3)		
SC-900T-1950			1950 (76.8)		
SC-900T-2130			2130 (83.9)		
SC-900T-2600			2600 (102.4)		
SC-900T-3000			3000 (118.1)		
SC-1100T-1950	1084 (42.7)	480 (18.9)	1950 (76.8)		
SC-1100T-2130			2130 (83.9)		
SC-1100T-2600			2600 (102.4)		
SC-1100T-3000			3000 (118.1)		
SC-1300T-2130	1284 (50.6)	600 (23.6)	2130 (83.9)		
SC-1300T-2600			2600 (102.4)		
SC-1300T-3000			3000 (118.1)		

## LARGE BEAM (1500-4500 TON) TRAVERSE ROBOTS

Model Number	Vertical Stroke, mm (in.)	Kick Stroke, mm (in.)	Traverse Stroke, mm (in.)	Payload, lbs.
<b>Two stage telescopic vertical arm</b>				
SC-1500T-2190	1465 (57.7)	680 (26.8)	2190 (86.2)	66.0
SC-1500T-2310			2310 (90.9)	
SC-1500T-2490			2490 (98.0)	
SC-1500T-3000			3000 (118.1)	
SC-1500T-3500			3500 (137.8)	
SC-1700T-2310	1700 (66.9)	800 (31.5)	2310 (90.9)	
SC-1700T-2490			2490 (98.0)	
SC-1700T-3000			3000 (118.1)	
SC-1700T-3500			3500 (137.8)	
SC-2000T-2490	1945 (76.6)	920 (36.2)	2490 (98.0)	
SC-2000T-3000			3000 (118.1)	
SC-2000T-3500			3500 (137.8)	
SC-2500T-3010	2465 (97.0)	1130 (44.5)	3010 (118.5)	110.0
SC-2500T-4000			4000 (157.5)	
SC-2500T-5000			5000 (196.9)	
SC-3000T-3010	2945 (115.9)	1310 (51.6)	3010 (118.5)	
SC-3000T-4000			4000 (157.5)	
SC-3000T-5000			5000 (196.9)	

\* Operating voltage: 220/3/60

# APEX SC SERIES

3-Axis Servo Driven  
Traversing Robots

## SMALL BEAM (80-1000 TON) TRAVERSE ROBOTS - SINGLE STAGE

Model Number	C (mm)	H (mm)	I (mm)	K (mm)	L (mm)	N (mm)
SC-900	864	1232	1710	2746	1691	360
SC-1100	1064	1352	1950	2986	1891	480
SC-1300	1264	1472	2130	3166	2091	600

Extension traverse available: 2600mm and 3000mm

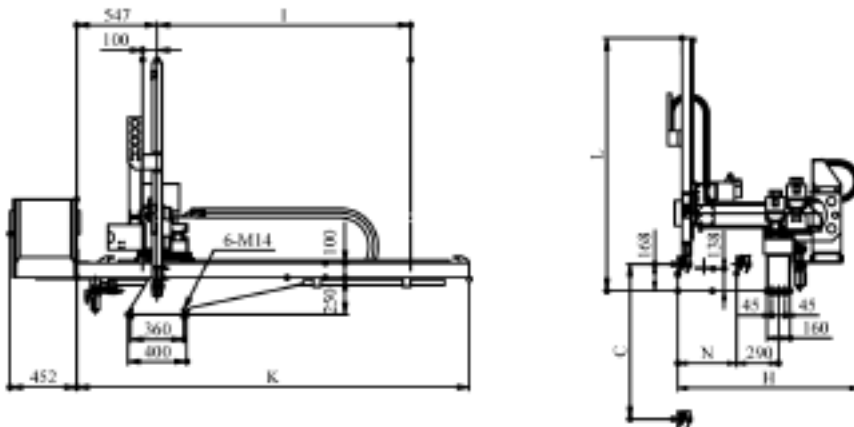

## SMALL BEAM (80-1000 TON) TRAVERSE ROBOTS - TWO STAGE TELESCOPIC

Model Number	C (mm)	H (mm)	I (mm)	K (mm)	L (mm)	N (mm)
SC-900T	900	1329	1710	2746	1318	360
SC-1100T	1084	1449	1950	2986	1398	480
SC-1300T	1284	1569	2130	3166	1498	600

Extension traverse available: 2600mm and 3000mm

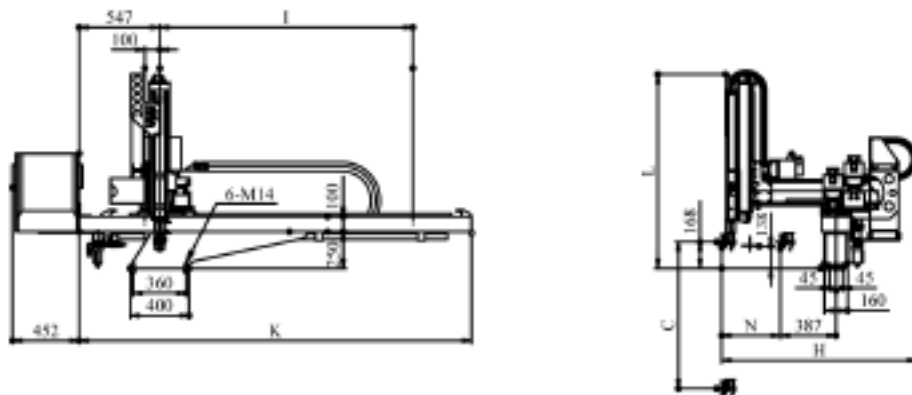

# APEX SC SERIES

3-Axis Servo Driven  
Traversing Robots

## LARGE BEAM (1500-4500 TON) TRAVERSE ROBOTS - TWO STAGE TELESCOPIC

Model Number	C (mm)	H (mm)	I (mm)	K (mm)	L (mm)	N (mm)
SC-1500T	1465	1818	2190	3156	1911	680
SC-1700T	1700	1938	2310	3276	2031	800
SC-2000T	1945	2058	2490	3456	2151	920

Extension traverse available: 3000mm and 3500mm

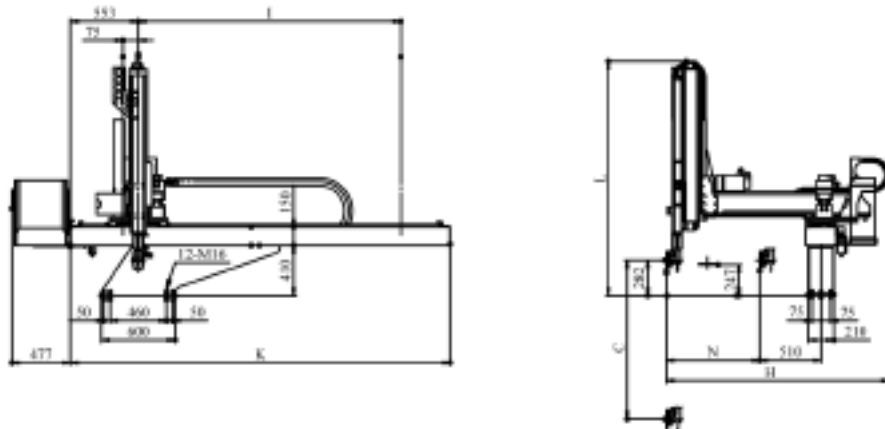

## LARGE BEAM (1500-4500 TON) TRAVERSE ROBOTS - TWO STAGE TELESCOPIC

Model Number	C (mm)	H (mm)	I (mm)	K (mm)	L (mm)	N (mm)
SC-2500T	2465	2330	3010	4005	2430	1130
SC-3000T	2945	2510	3010	4005	2670	1310

Extension traverse available: 4000mm and 5000mm

