

APEX SB SERIES



3-Axis Servo Driven Traversing Robots

PIN-POINT ACCURACY AT AN AFFORDABLE PRICE

The 3-axis servo driven SB Series traverse robot combines versatility with pin-point accuracy creating a reliable robot at a very affordable price. The SB Series offers superior parts removal capability by reducing the difficulty and lowering the cost to build End-of-Arm Tooling. The SB is also great for applications such as rejection, test-mold and weight programs, as well as cycle counting.

Equipped with 3-axis AC brushless servo motors. The three axes can be synchronized to move to designated points at the same time. All this with accuracy within ± 0.1 mm.

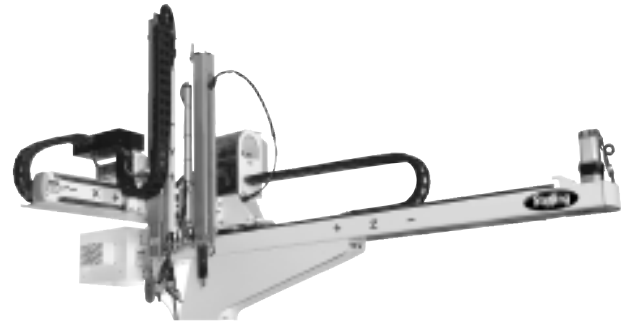

Features

- High-precision linear guide systems - enhanced motion and repeatability
- All-axis AC servo motor drive for enhanced in-mold and secondary positioning
- One (1) vacuum circuit and one (1) pressure circuits with verification
- End-of-arm tooling "quick-change" system - robot and EOAT side included
- Quick disconnects for electrical connections
- Telescoping vertical arm for low overhead clearance and enhanced speed
- Spare I/O - fourteen (14) inputs/fourteen (14) outputs
- SPI / Euromap 12
- Air requirement is: 80 PSI clean dry air
- Electrical requirement: 220 VAC, three phase, 60 hertz
- Available in operator or non-operator side unload configurations
- One (1) year parts warranty (excluding on-site labor / travel expenses)
- Two (2) year warranty on the hand-held pendant

Options

- A-axis pneumatic wrist rotation for part/runner orientation
- Additional pressure and/or vacuum circuit(s)
- I/O expansion pack - up to 30 I/O
- Additional EOAT quick-change plates
- Euromap 67 interface
- Non-SPI interface

APEX SB SERIES

3-Axis Servo Driven Traversing Robots

SINGLE STAGE SINGLE ARM SPECIFICATIONS (MM)

Model No.	B	C	D	E	F	G	H	I	K	L	N
SB-700	90	130	338	669	167	137	1000	1525	2941	1519	446
SB-900	90	130	338	789	167	137	1120	1765	3181	1719	566
SB-1200	90	130	338	909	167	137	1240	2005	3421	2019	686

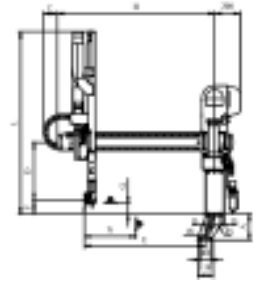

Single-Arm

SINGLE-STAGE SUB-ARM SPECIFICATIONS (MM)

Model No.	B	C	D	E	F	G	H	I	K	L	N	P	Q
SB-700S	90	130	338	669	167	137	1000	1525	2941	1519	446	170	1510
SB-900S	90	130	338	789	167	137	1120	1765	3181	1719	566	170	1710

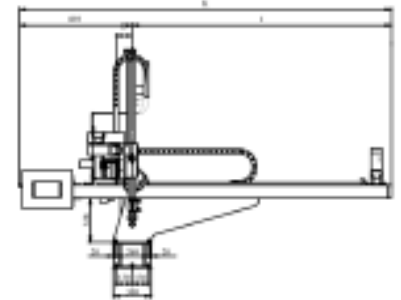

Single-Arm and Sub-Arm

TELESCOPIC SINGLE ARM SPECIFICATIONS (MM)

Model No.	B	C	D	E	F	G	H	I	K	L	N	P	Q
SB-700T	69	190	410	676	140	110	1000	1525	2941	1200	284	195	1155
SB-900T	69	190	410	796	140	110	1120	1765	3181	1300	404	195	1255
SB-1200T	69	190	410	916	140	110	1120	1765	3181	1450	487	226	1405

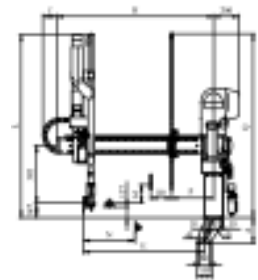

Sub-Arm

TELESCOPIC SUB-ARM SPECIFICATIONS (MM)

Model No.	B	C	D	E	F	G	H	I	K	L	N	P	Q
SB-700TS	69	190	410	676	140	110	1000	1525	2941	1200	284	195	1155
SB-900TS	69	190	410	796	140	110	1120	1765	3181	1300	404	195	1255
SB-1200TS	69	190	410	916	140	110	1120	1765	3181	1450	487	226	1405

SPECIFICATIONS (MM)

Model		Dry Cycle (sec.)		I.M.M. Range (tons)	Stroke (mm)				Max. Payload (lbs)	Net Weight (kgs)	Comp. Air Pressure	
		Take-Out	Cycle		Strip		Vertical					Traverse
					main	sub	main	sub				
SB-700	Single-stage, single arm	1.2	9	80-200	446	-	664	-	1525	13.2 (sub arm 6.6)	230	
SB-700S	Single-stage, sub arm				343	100	664	750			240	
SB-700T	Telescopic, single arm				417	-	684	-			250	
SB-700TS	Telescopic, sub arm				284	100	684	750			260	
SB-900	Single-stage, single arm	1.3	10	200-450	566	-	864	-	1765	13.2 (sub arm 6.6)	235	
SB-900S	Single-stage, sub arm				463	100	864	950			250	
SB-900T	Telescopic, single arm				597	-	884	-			260	
SB-900TS	Telescopic, sub arm				404	100	884	950			270	
SB-1200	Single-stage, single arm	1.4	11	450-650	686	-	1164	-	2005	13.2 (sub arm 6.6)	240	
SB-1200T	Telescopic, single arm				717	-	1184	-			265	
SB-1200TS	Telescopic, sub arm				487	100	1184	1250			280	

Power Source: AC 220V Single Phase