



SDAA Dryer with Standard AP0 Control
Reference Manual (PN: 882.00290.00) for
Complete Operation and Installation Instructions
 (Available online at www.acscustomerservice.com)

Quick-Start Pre-Startup Checklists

1. Check the process and return hoses for tight connections.
2. Check all companion equipment, such as the drying hopper; verify the loading system is ready for operation.
3. Verify all dryer electrical connections are tight.
4. Verify the thermocouple is properly installed at the hopper inlet.
5. Verify temperature unit/scale (°F or °C).

Quick Startup Checklist

1. Turn **ON** the power disconnect switch in your power drop, then turn **ON** the power disconnect switch on the dryer.
2. Turn the dryer **ON/OFF** switch to **ON** to energize the display panel.
3. Close the slide gate at the bottom of the drying hopper.
4. Fill the drying hopper with material.
5. Turn the dryer **ON** switch to **START** to start the dryer. The process blower starts.
6. Make sure the blower turns in the correct direction.
 - a. Disconnect the hose from drying hopper to the filter.
 - b. Quickly turn the switch to **START** position and back to **OFF**. (You should feel suction at the inlet of the filter).
 - c. Secure the hose back in place.



Setting the Redundant Safety Controller

- The Redundant Safety Controller alarm setting is changed by pressing the up and down keys, which inputs the alarm value.
- The upper display reading indicates the Process Value, while the lower display indicates the High Point Setting alarm value.

Auto-Tuning the Dryer

1. For Auto-tuning, press the Level Key once.
2. The Auto-tuning screen will show with the setting **OFF**.
3. Press the **UP** key to change the setting to **ON**.
4. Press the Level Key again to go back to the Temperature Screen.
5. After 10 to 20 minutes the flashing of actual temperature stops, meaning auto-tuning has finished.

Setting the Process Air Temperature

1. Press  to raise the recommended material drying temperature.
2. Press  to lower the recommended material drying temperature.

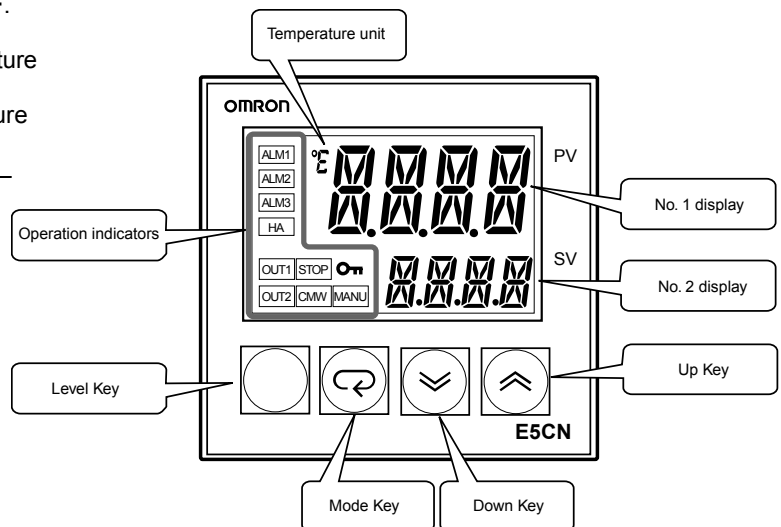
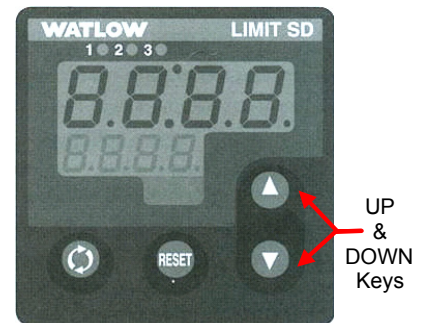
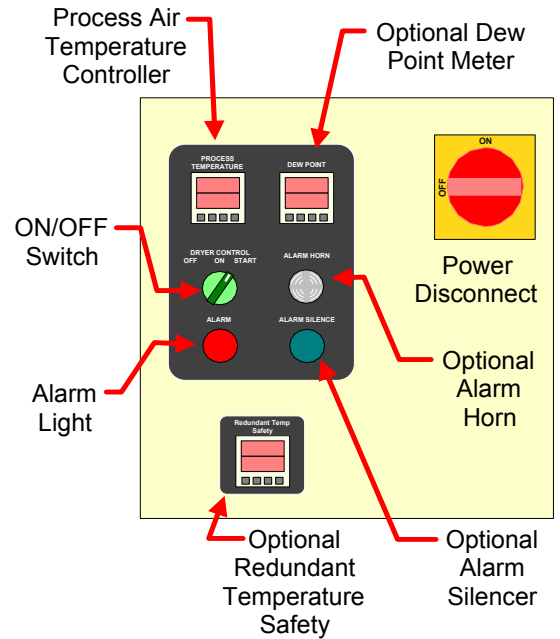



SDAA Dryer with Standard AP0 Control
Reference Manual (PN: 882.00290.00) for
Complete Operation and Installation Instructions
(Available online at www.acscustomerservice.com)

Maintenance

Filters: Recommendations for Cleaning and Replacing

1. Turn off and/or lock out electrical power to the dryer.
2. Loosen the clamp, and remove the dust can.
3. Remove the thumb nut, on the center retaining rod, to remove the filter cartridge.
4. Pull the filter cartridge out.

Vacuuming

- Try vacuum-cleaning a soiled filter first. (Vacuuming removes most large particles and surface contaminants, and may suffice for the first time you clean a filter).
- Use a commercial-duty (recommended) or household vacuum cleaner. Vacuum the filter from the air intake (dirty) side only.

Cleaning with Compressed Air

1. Blow clean, dry, compressed air up and down the pleats, blowing out the filter from the inside out.
2. Remove loose dirt from the filter with compressed air or vacuum from the outside.
3. Inspect the filter element. Briefly hold a light bulb behind the element and look for any fatigued paper or residual dirt.
4. Inspect for holes and tears by looking through the filter toward a bright light. Check for damaged gaskets or dented metal parts.

Note: Do not re-use a damaged filter!

Cooling Coils: Cleaning and Replacement Procedures

1. Shut down the dryer, tag out and lock out the controls if necessary.
2. Shut the water off to the cooling coil.
3. Remove the four 10-32 bolts.
4. Gently slide the cooling coil out.
5. Visually inspect the coil for leaks, dirt, and any sign of volatiles.
6. Blow the dust out, or if the coil is covered with plasticizer, steam clean it.
7. Place the coil back in its housing. Make sure the gasket is undamaged, replace if necessary.
8. Inset the four 10-32 bolts back in place.
9. Turn the water to the cooling coil back on.

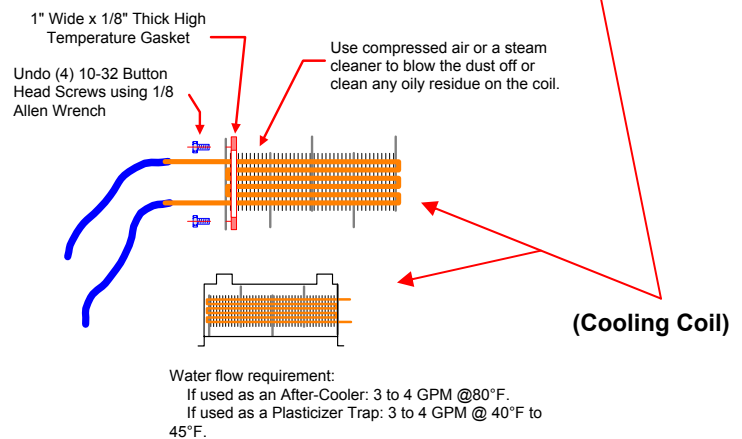
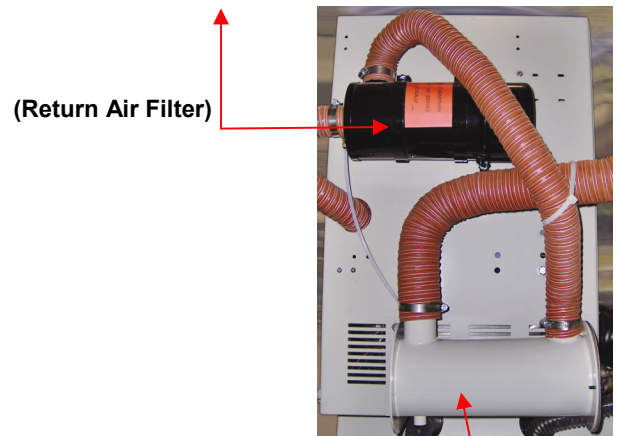
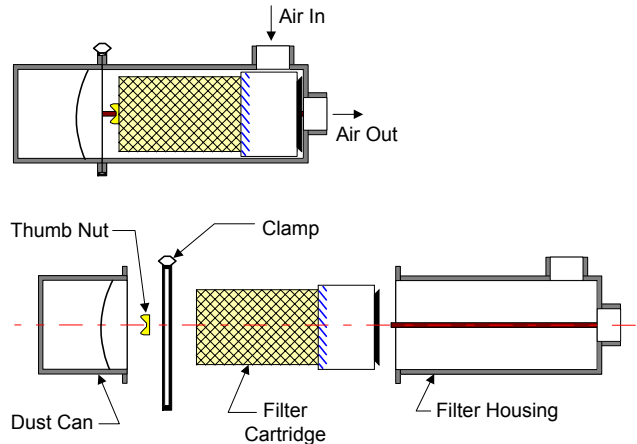



SDAA Dryer with Standard AP0 Control
Reference Manual (PN: 882.00290.00) for
Complete Operation and Installation Instructions
 (Available online at www.acscustomerservice.com)

Spare Parts List

Model	Filter	Desiccant Replacement Beads	Regeneration Thermocouple	Process Thermocouple	Gasket
SDAA 25/50/100	Standard Temperature – Part # W00052474 High Temperature – Part # 161.00194.00	13 X Beads – Part # W00018051	25 ONLY – 96" Long – Part # A0568474 50/100 ONLY – 96" Long – Part # A0543758	15' Long (Braided Design) – Part # A0568466 72" Long (Braided Design) – Part # A0568473	Standard and High Temperature – Part # A0566839

Note: Refer to the main manual and wiring diagram for a complete Spare Parts List

Troubleshooting – Quick Guide

(See next page for more troubleshooting)

Alarm Message	Cause	Corrective Action	Dryer Status
High Dew Point	The dew point reading has exceeded the dew point alarm set point.	Make sure the process air filter is clean. Clean or replace if necessary.	Dryer Normal: -Process blower ON. -Process heaters ON. -Regen heaters OFF. -Alarm light is ON. -Alarm horn is ON.
		Make sure all the hose connections and all the components of the dryer have proper seals on them (i.e. desiccant tanks, heater box, filters, after-cooler). Tighten the connections and replace any damaged seals.	
		Make sure the regeneration timing cycle matches the specs. If not, contact the Service Department.	
		Desiccant may be contaminated and blocking the air flow. Check desiccant, replace if necessary.	
Process High Temp	The process temperature has exceeded the alarm set point	Make sure the process filter is clean. Clean or replace.	Dryer Shuts Down: -Process blower OFF. -Process heaters OFF. -Regen heaters OFF. -Alarm light is ON. -Alarm horn is ON.
		Double check the alarm set point is at 35°F	
		Check the positioning of the thermocouple inside the air inlet of the drying hopper. The tip of the thermocouple should be centered in the tube, and not touching any metal part of the tube.	
		The drying temperature set point is lower than dryer capabilities. Check the dryer specs.	
		Make sure all the hose connections are tight.	
Make sure the regeneration timing cycle matches the specs. If not, contact the Service Department.			



SDAA Dryer with Standard AP0 Control
Reference Manual (PN: 882.00290.00) for
Complete Operation and Installation Instructions
 (Available online at www.acscustomerservice.com)

Troubleshooting (cont'd.)

Alarm Message	Cause	Corrective Action	Dryer Status
Vault Positioning Fault	The limit switch on the valve may not have been wired correctly.	The switch is indicating the incorrect desiccant tank is in regeneration. Check the wiring of the switch against the wiring diagram. Make sure all the wire connections are tight.	Dryer Shuts Down: -Process blower OFF. -Process heaters OFF. -Regen heaters OFF. -Alarm light is ON. -Alarm horn is ON.
Valve Motor Override	The valve has made enough rotations and the correct position of the valve was not detected.	Limit switch may be out of position. Re-adjust the switch to make sure it trips when it is at the high position, and it does not touch the cam when it is at the low position. Limit switch may be faulty. Replace the switch and make sure the wires are connected correctly.	
High Temp	The process temperature has exceeded the alarm set point.	Make sure the process filter is clean. Clean or replace if necessary. Double check the alarm set point is at 35°F.	Dryer Shuts Down: -Process blower OFF. -Process heaters OFF. -Regen heaters OFF. -Alarm light is ON. -Alarm horn is ON.
	The high temperature snap switch in the process heater box has tripped.	Check the positioning of the thermocouple inside the air inlet of the drying hopper. The tip of the thermocouple should be centered to the tube, and not touching any metal of the tube.	
		The drying temperature set point is lower than dryer capabilities. Check the dryer specs.	
		Make sure all the hose connections are tight.	
	The high temperature snap switch in the regeneration heater boxes has tripped.	Make sure the regeneration timing cycle matches the specs. If not, contact the Service Department.	
		The process heater contactor has failed in the closed position. Check heater contactor, replace if necessary.	
		Check the Process Heater box high temperature snap switch, replace if necessary.	
		The Regeneration heater contactor has failed in the closed position. Check heater contactor, replace if necessary.	
	Check the high temperature snap switches on the regeneration heater mounting plates, replace if necessary.		
Valve MTR	The limit switch on the valve may not have been wired correctly.	Limit switch may be out of position. Re-adjust the switch so it trips when it is at the high position, and avoids touching the cam when it is at the low position.	Dryer Shuts Down: -Process blower OFF. -Process heaters OFF. -Regen heaters OFF. -Alarm light is ON. -Alarm horn is ON.
	The valve has made enough rotations and the correct position of the valve was not detected.	The switch is indicating the incorrect desiccant tank is in regeneration. Check the wiring of the switch against the wiring diagram. Make sure all the wire connections are tight.	
	Valve motor or not connected to 120V at PLC/Circuit.	Limit switch may be faulty. Replace the switch and make sure the wires are connected correctly.	