

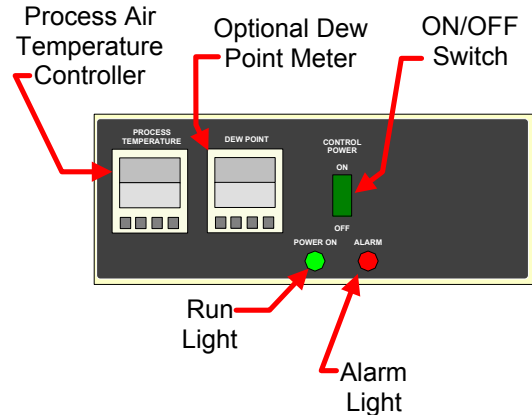

**SDA Dryer with Standard AP0 Control**  
**Reference Manual (PN: 882.00291.00) for**  
**Complete Operation and Installation Instructions**  
 (Available online at [www.acscustomerservice.com](http://www.acscustomerservice.com))

### Quick Start Pre-Startup Checklists

1. Check the process and return hoses for tight connections.
2. Check all companion equipment, such as the drying hopper; verify the loading system is ready for operation.
3. Verify all dryer electrical connections are tight.
4. Verify the thermocouple is properly installed at the hopper inlet.
5. Verify temperature unit/scale (°F or °C).



### Quick Startup Checklist

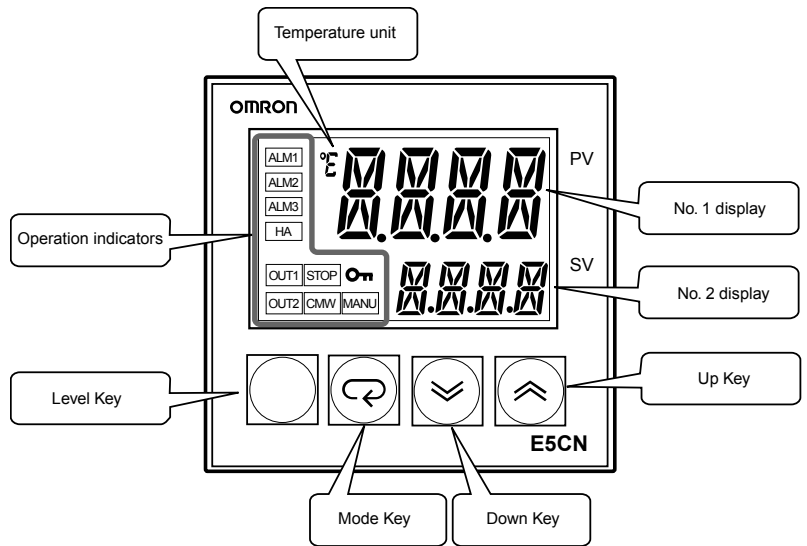

1. Turn **ON** the power disconnect switch in your power drop, then turn **ON** the power disconnect switch on the dryer.
2. Turn the dryer **ON/OFF** switch to **ON** to energize the display panel. The process blower starts.
3. Close the slide gate at the bottom of the drying hopper.
4. Fill the drying hopper with material.
5. Make sure the blower turns in the correct direction.
  - a. Disconnect the hose from drying hopper to the filter.
  - b. Quickly turn the **ON/OFF** switch to **OFF**. (You should feel suction at the inlet of the filter).
  - c. Secure the hose back in place.



### Auto-Tuning the Dryer

1. For Auto-tuning, press the level key once.
2. The Auto-tuning screen will show with the setting **OFF**.
3. Press the **UP** arrow to change the setting to **ON**.
4. Press the level key again to go back to the Temperature Screen.
5. After 10 to 20 minutes the flashing of actual temperature stops, meaning auto-tuning has finished.

### Setting the Process Air Temperature

1. Press  to raise the recommended material drying temperature.
2. Press  to lower the recommended material drying temperature.

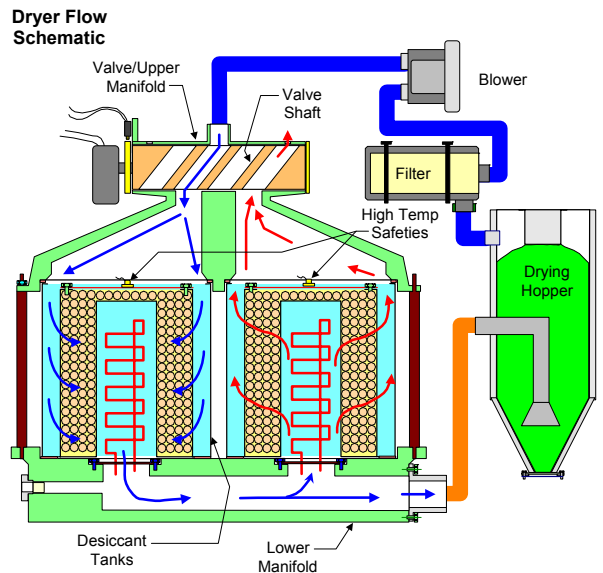



**SDA Dryer with Standard AP0 Control**  
Reference Manual (PN: 882.00291.00) for  
Complete Operation and Installation Instructions  
(Available online at [www.acscustomerservice.com](http://www.acscustomerservice.com))

## Maintenance

### Filters: Recommendations for Cleaning and Replacing

1. Turn off and/or lock out electrical power to the dryer.
2. Loosen the clamp, and remove the dust can.
3. Remove the thumb nut, on the center retaining rod, to remove the filter cartridge.
4. Pull the filter cartridge out.

### Vacuuming

- Try vacuum-cleaning a soiled filter first. Vacuuming removes most large particles and surface contaminants, and may suffice for the first time you clean a filter.
- Use a commercial-duty (recommended) or household vacuum cleaner. Vacuum the filter from the air intake (dirty) side only.

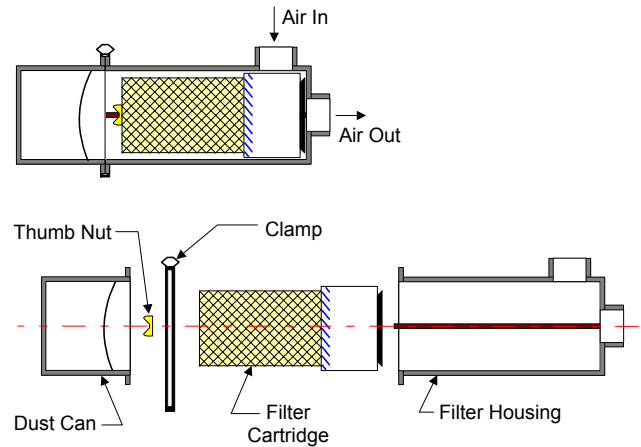

### Cleaning with Compressed Air

1. Blow clean, dry, compressed air up and down the pleats, blowing out the filter from the inside out.
2. Remove loose dirt from the filter with compressed air or vacuum from the outside.
3. Inspect the filter element. Briefly hold a light bulb behind the element and look for any fatigued paper or residual dirt.
4. Inspect for holes and tears by looking through the filter toward a bright light. Check for damaged gaskets or dented metal parts.

**Note: Do not re-use a damaged filter!**

### Cooling Coils: Cleaning and Replacement Procedures

1. Shut down the dryer, tag out, and lock out the controls if necessary.
2. Shut the water off to the cooling coil.
3. Remove the four 10-32 bolts.
4. Gently slide the cooling coil out.
5. Visually inspect the coil for leaks, dirt, and any sign of volatiles.
6. Blow the dust out, or if the coil is covered with plasticizer, steam clean it.
7. Place the coil back in its housing. Make sure the gasket is undamaged, replace if necessary.
8. Inset the four 10-32 bolts back in place.
9. Turn the water to the cooling coil back on.

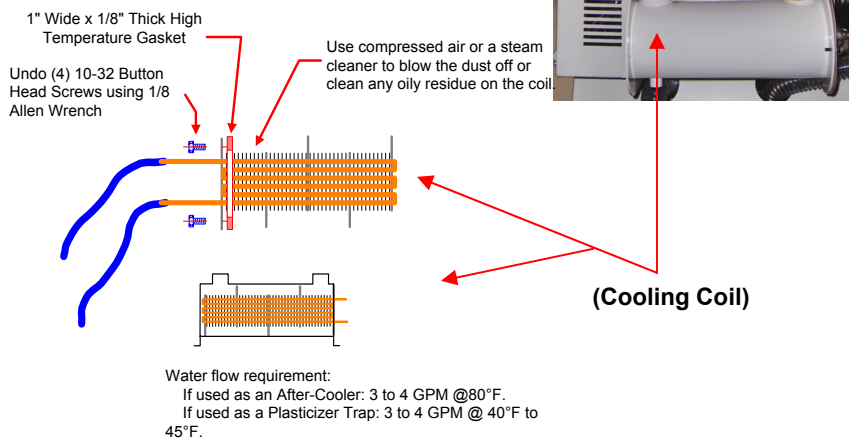



**SDA Dryer with Standard AP0 Control**  
**Reference Manual (PN: 882.00291.00) for**  
**Complete Operation and Installation Instructions**  
 (Available online at [www.acscustomerservice.com](http://www.acscustomerservice.com))

### Spare Parts List

Model	Filter	Desiccant Replacement Beads	Regeneration Thermocouple	Process Thermocouple	Gasket
SDA 25/50/100	Standard Temperature – Part # W00052474 High Temperature – Part # 161.00194.00	13 X Beads – Part # W00018051	N/A	15' Long (Braided Design) – Part # A0568466 72" Long (Braided Design) – Part # A0568473	Standard and High Temperature – Part # A0566839

### Troubleshooting – Quick Guide

(See next page for more troubleshooting)

Alarm Message	Cause	Corrective Action	Dryer Status
Proc Blwr	The process blower pressure switch did not detect enough pressure.	Make sure the process air filter is clean. Clean or replace if necessary.	<b>Dryer Shuts down:</b> -Process blower OFF. -Process heaters OFF. -Regen heaters OFF. -Alarm light is ON. -Alarm horn is ON.
		Check the rotation of the blower.	
		Check the pressure switch hose connection. Replace hoses or the pressure switch.	
	Process blower overload has tripped.	Check the over load rating against the wiring diagram. Adjust accordingly.	
		Check the wiring of the blower. Make sure it is wired for the proper voltage.	
	Process blower motor has failed.	Check the process blower fuses for any fault. Replace if necessary.	
		Check the blower motor starter. Replace if necessary	
		Check the blower motor. Replace if necessary.	
		Check the incoming voltage against the nameplate of the dryer.	
	Lose contacts or wires.	Check all connections. Make sure connections are secure. Adjust if necessary.	



**SDA Dryer with Standard AP0 Control**  
**Reference Manual (PN: 882.00291.00) for**  
**Complete Operation and Installation Instructions**  
 (Available online at [www.acscustomerservice.com](http://www.acscustomerservice.com))

**Troubleshooting (cont'd.)**

Alarm Message	Cause	Corrective Action	Dryer Status
High Temp	The process temperature has exceeded the alarm set point.	Make sure the process filter is clean. Clean or replace if necessary.	<b>Dryer Shuts Down:</b>  -Process blower OFF. -Process heaters OFF. -Regen heaters OFF. -Alarm light is ON. -Alarm horn is ON.
		Double check the alarm set point is at 35°F.	
	The high temperature snap switch in the process heater box has tripped	Check the positioning of the thermocouple inside the air inlet of the drying hopper. The tip of the thermocouple should be centered in the tube, and not touching any metal of the tube.	
		The drying temperature set point is lower than dryer capabilities. Check the dryer specs.	
		Make sure all the hose connections are tight.	
		Make sure the regeneration timing cycle matches the specs. If not, contact the Service Department.	
	The high temperature snap switch in the regeneration heater boxes has tripped.	The process heater contactor has failed in the closed position. Check heater contactor, replace if necessary.	
		Check the Process Heater box high temperature snap switch, replace if necessary.	
		The Regeneration heater contactor has failed in the closed position. Check heater contactor, replace if necessary.	
		Check the high temperature snap switches on the regeneration heater mounting plates, replace if necessary.	
Valve MTR	The limit switch on the valve may not have been wired correctly.	Limit switch may be out of position. Re-adjust the switch so it trips when it is at the high position, and avoids touching the cam when it is at the low position.	<b>Dryer Shuts Down:</b>  -Process blower OFF. -Process heaters OFF. -Regen heaters OFF. -Alarm light is ON. -Alarm horn is ON.
	The valve has made enough rotations and the correct position of the valve was not detected.	The switch is indicating the incorrect desiccant tank is in regeneration. Check the wiring of the switch against the wiring diagram. Make sure all the wire connections are tight.	
	Valve motor or not connected to 120V at PLC/Circuit.	Limit switch may be faulty. Replace the switch and make sure the wires are connected correctly.	