



CONDENSATE PUMPS 4200 SERIES CAST IRON TANK

ENERGY EFFICIENT DESIGN, PROVEN PERFORMANCE AND THE RIGHT SIZE FOR YOUR APPLICATION

Sterlco® Condensate Return Pumps set new standards of performance. Reliable and efficient, each unit features heavy-duty cast iron receivers for long operating life. In addition, 3450 RPM motors assure maximum efficiency while maintaining minimum motor horsepower. Available in a wide range of sizes, these U.S. made pumps have just the right accessories and options to meet your unique needs. What's more, a nationwide network of stocking distributors means fast, easy, year-round access to pumps and replacement parts.



FEATURES

- Heavy-duty cast iron receivers
- Simplex or duplex construction
- Bronze fitted centrifugal pumps
- Energy efficient 3450 RPM motors
- Automatic venting
- "Sterl-Seal" ceramic pump seal
- Heavy-duty float switch
- Wide range of options and accessories

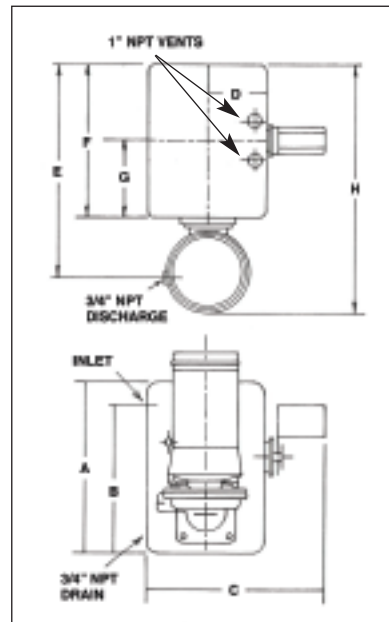

**G SERIES
6 GALLON TANK**

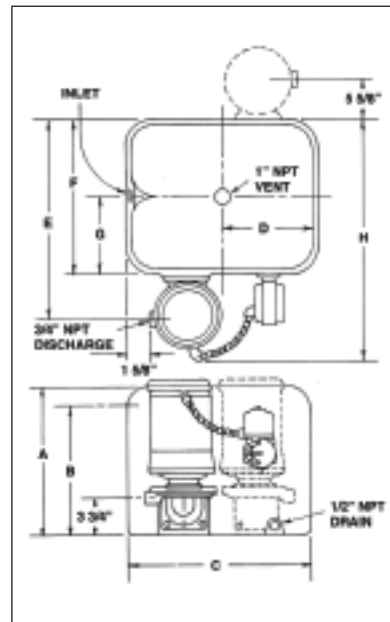

**G SERIES
13.5 GALLON TANK**

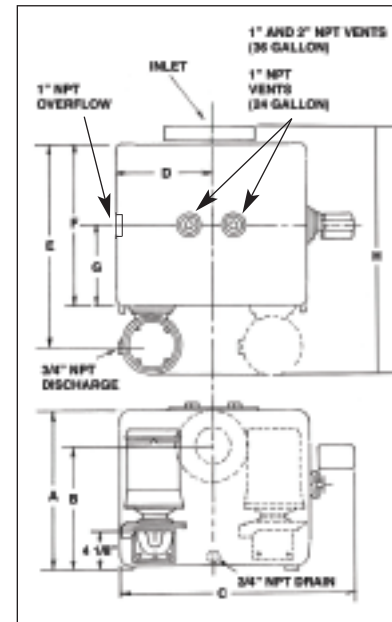

**G SERIES
24-36 GALLON TANKS**

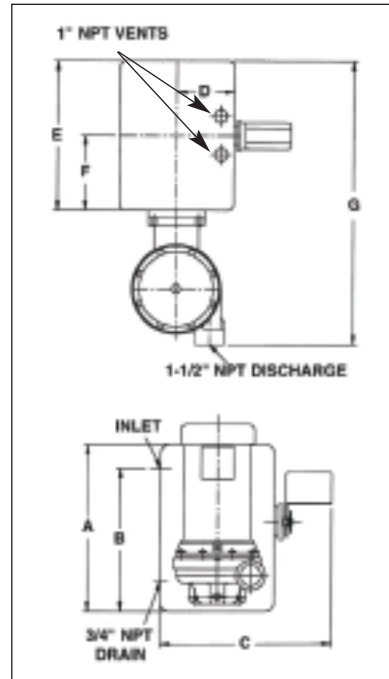

**J SERIES
6 GALLON TANK**

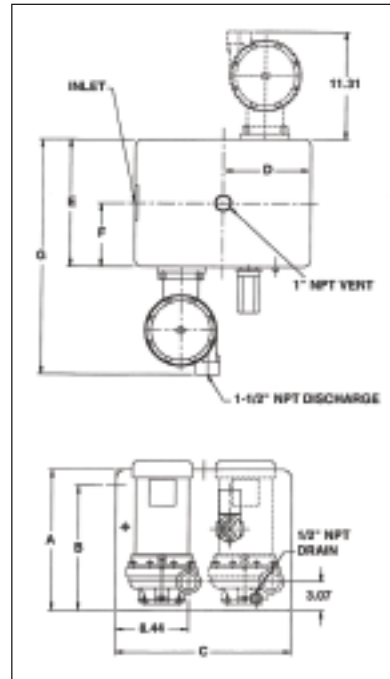

**J SERIES
13.5 GALLON TANK**

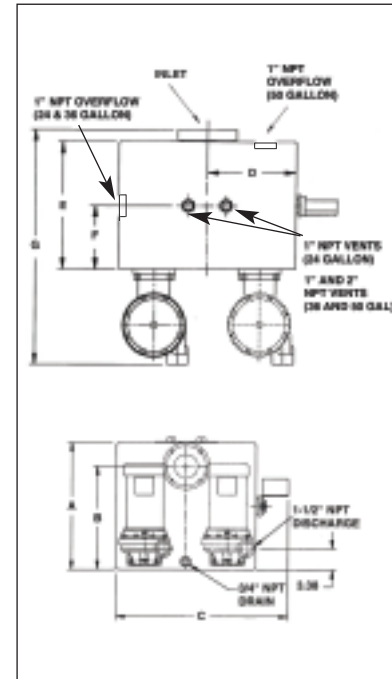

**J SERIES
24-50 GALLON TANKS**

Receiver Size	A	B	C	D	E	F	G	H	Inlet
6 G	14.50	12.50	14.50	4.80	18.25	12.62	6.31	20.44	2"
13.5 G	14.88	13.19	18.50	9.25	19.12	13.50	6.75	24.00	2"
24 G	19.13	15.63	25.84	10.50	20.04	15.00	7.50	22.82	2"
36 G	18.63	15.13	27.34	11.25	27.54	22.50	11.25	31.76	3"
6 J	14.50	12.50	14.50	4.82	12.62	6.31	24.06	N/A	2"
13.5 J	14.88	13.19	18.50	9.25	13.50	6.75	24.94	N/A	2"
24 J	19.13	15.63	25.84	10.50	15.00	7.50	26.44	N/A	2"
36 J	18.63	15.13	27.34	11.25	22.50	11.25	35.38	N/A	3"
50 J	18.63	15.13	27.34	11.25	31.00	15.50	43.88	N/A	3"

75 and 110 Gallon oversized receivers are available



2900 S 160th Street
New Berlin, Wisconsin 53151
Tel. 262.641.3808 Toll Free 888.777.4085 Fax 262.641.8625

© 2007 Sterling www.steamcontrolproducts.com

STERLCO® PRODUCTS INCLUDE: HAND RADIATOR VALVES • THERMOSTATIC TRAPS • FLOAT AND THERMOSTATIC TRAPS • INVERTED BUCKET TRAPS • CAST IRON STRAINERS • BRASS STRAINERS • TANK AND PROCESS TEMPERATURE CONTROL VALVES • BOILER FEED UNITS • CONDENSATE PUMPS



Built-In Features For Precise, Dependable Performance

- **Motors:** Heavy-duty, ballbearing, close-coupled pump motors with stainless steel shaft. 3450 RPM for greater efficiency and more economical operation.
- **Float Switch:** Two-pole, drip proof case, stainless steel float and float rod, double-break silver-to-silver contacts. Float travel adjustment is easy, visible and accessible.
- **Automatic Venting:** Provides for efficient operation and long life by venting air and flushing seal area.
- **Large Tanks:** Plenty of capacity for maximum rating of pump. Return inlet is low. Occupies a minimum of floor space.
- **Centrifugal Pump:** Offers a wide range of pressures and GPM. Unique design features provide for ease of servicing.
- **Impeller:** Made of brass for long life. Efficient design provides maximum capacity, minimum motor load.
- **“SterlSeal” Pump Seal (A):** Features the ultimate in ceramic technology for exceptionally long life. Because the seal runs on the bronze impeller hub, the motor shaft is literally outside the pump. Consequently, the shaft is not exposed to corrosion by condensate. Rated for temperatures up to 250°F.
- **Isolation Valve (B):** Optional on 4200 Series Condensate Pumps

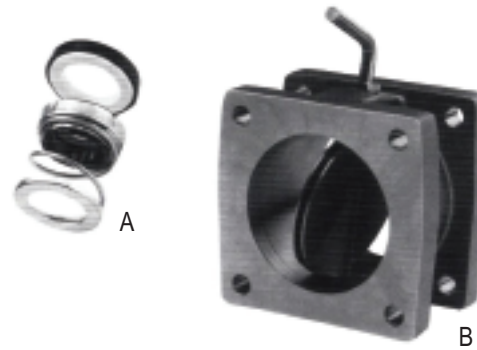

Complete NEMA 12 Control Panel (Optional)

Motor Circuit Protector, HOA Selector Switch, External Reset, Control Circuit Transformer, Pilot Light (pump running), Removable Mounting Plate and Terminal Strip in a Single NEMA 12 Enclosure, Mounted and Wired, with Single Point Power Connection.

Special Options

- Mechanical and electrical alternators
- Gauge glass
- Thermometer
- Discharge pressure gauges
- Isolation valves
- Special motor construction, such as totally enclosed and explosion proof, is available
- Magnetic starters with H-O-A selector switches
- 1750 RPM motors, larger pumping capacities and higher discharge pressures - consult factory
- Complete NEMA 12 Control Panel

4200 Series Engineering and Capacity Data

CAPACITY SQ. FT. E.D.R.	DISCHARGE PRESSURE P.S.I.	PUMP CAP. G.P.M.	MOTOR H.P.	REC. CAP. GAL.	UNIT MODEL NO.		SHIPPING WT. LBS.	
					SIMPLEX	DUPLEX	SIMPLEX	DUPLEX
2,000	20	3	1/3	6	4222-G		150	
4,000		6	1/3	6	4224-G		150	
6,000		9	1/3	13.5	4226-G	4226-GD	260	295
8,000		12	1/3	13.5	4228-G	4228-GD	260	295
10,000	20	15	1/2	13.5	42210-G	42210-GD	260	295
15,000		22.5	1/2	24	42215-G	42215-GD	300	335
20,000		30	3/4	36	42220-G	42220-GD	410	445
25,000	20	37.5	3/4	36	42225-J	42225-JD	350	420
30,000		45	1	36	42230-J	42230-JD	355	430
40,000	20	60	1-1/2	50	42240-J	42240-JD	420	500
50,000	20	75	2	50	42250-J	42250-JD	425	510
2,000	30	3	1/2	6	4232-J		165	
4,000		6	1/2	6	4234-J		165	
6,000		9	1/2	13.5	4236-J	4236-JD	295	360
8,000		12	1/2	13.5	4238-J	4238-JD	295	360
10,000		15	3/4	13.5	42310-J	42310-JD	300	365
15,000	30	22.5	1	24	42315-J	42315-JD	305	380
20,000		30	1	36	42320-J	42320-JD	355	430
25,000	30	37.5	1	36	42325-J	42325-JD	355	430
30,000		45	1-1/2	36	42330-J	42330-JD	360	440
40,000	30	60	2	50	42340-J	42340-JD	425	510
50,000	30	75	3	50	42350-J	42350-JD	435	525
2,000	40	3	1	6	4242-J		170	
4,000		6	1	6	4244-J		170	
6,000		9	1	13.5	4246-J	4246-JD	295	360
8,000		12	1	13.5	4248-J	4248-JD	295	360
10,000		15	1	13.5	42410-J	42410-JD	295	360
15,000	40	22.5	1-1/2	24	42415-J	42415-JD	310	390
20,000		30	1-1/2	36	42420-J	42420-JD	360	440
25,000	40	37.5	1-1/2	36	42425-J	42425-JD	360	440
30,000		45	2	36	42430-J	42430-JD	365	450
40,000	40	60	2	50	42440-J	42440-JD	425	510
50,000	40	75	3	50	42450-J	42450-JD	435	525
2,000	50	3	2	6	4252-J		175	
4,000		6	2	6	4254-J		175	
6,000		9	2	13.5	4256-J	4256-JD	315	395
8,000		12	2	13.5	4258-J	4258-JD	315	395
10,000		15	2	13.5	42510-J	42510-JD	315	395
15,000	50	22.5	2	24	42515-J	42515-JD	330	415
20,000		30	3	36	42520-J	42520-JD	370	460
25,000	50	37.5	3	36	42525-J	42525-JD	370	460
30,000		45	3	36	42530-J	42530-JD	370	460
40,000	50	60	5	50	42540-J	42540-JD	445	535
50,000	50	75	5	50	42550-J	42550-JD	445	535

Sample Specification

Furnish and install, where indicated on plans, a Sterling 4200 Series (simplex or duplex) condensate pump, having a capacity of _____ sq. ft. E.D.R., _____ GPM against a discharge pressure of _____ PSI. The receiver shall have a capacity of _____ gallons and be of heavy-duty cast iron construction. Pump(s) shall be of the centrifugal type with two-piece enclosed brass impeller, cast iron housing, high temperature (250°F) mechanical seal

and stainless steel motor shaft.

The float switch shall be two-pole with plastic case, stainless steel float and shaft, and double-break silver contacts. A flat perforated brass strainer shall be provided at the inlet to the pump from the tank. The motor(s) shall be vertical, 3450 RPM, _____ phase, _____ volt, 60 cycle, _____ H.P. The complete unit is to be factory assembled and tested prior to shipment.